

accuraspray CS

Guide d'installation rapide

Monitoring en ligne
des procédés de projection à froid
sur le plancher de production



tecnar

Innovate to differentiate.

Avant de commencer

Déballer les pièces

La boîte doit contenir les objets suivants :

1. Contrôleur
2. Unité IHM
3. Tête de capteur
4. Filtre à air et tuyaux
5. Pyromètre de substrat et son support (en option)
6. Câble de communication, câble d'alimentation du laser et câble de l'interrupteur de sécurité
7. Lunettes de sécurité

Ouvrez la boîte avec précaution, sortez-en les objets représentés, et placez le tout sur une surface de travail.

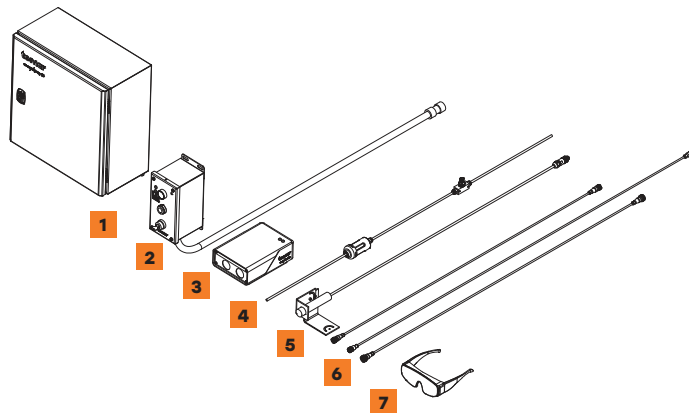

Register Now
Activate your warranty.
Get your free virtual training.



**Registration
Using QR Code
or online :**
spraysensors.tecnar.com/registration

Activez votre garantie et obtenez plusieurs autres avantages.

Notre processus d'enregistrement facile vous permet de tirer le meilleur parti de votre capteur et d'avoir l'esprit tranquille grâce à votre garantie.

- Obtenir une formation virtuelle gratuite
- Télécharger le manuel et les procédures
- Recevoir des alertes de mise à jour
- Discuter avec l'équipe technique
- Bénéficier de votre garantie



Avertissement concernant les produits laser de classe 4 :
Danger : rayonnement laser invisible.
Éviter l'exposition des yeux ou de la peau aux rayonnements directs ou diffus. (Longueur d'onde émise : 900 - 1000 nm, puissance de sortie maximale : 40 W)
Veuillez vous référer au manuel d'utilisation 40101-00075 section sécurité laser pour plus d'informations.

1. Installing the sensor head

Where to install

Install the sensor head in the spray booth where the robot (spray gun) can easily reach it. It should be a permanent place so the robot can repeatedly reach the sensor head. Also ensure that the sensor head does not interfere with normal spraying operations.

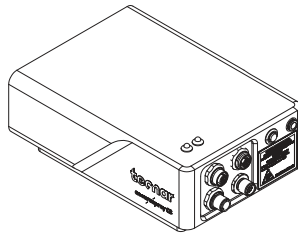

2. Installation procedure

Install the sensor head, using the 4 mounting holes, on a sturdy mounting plate that does not vibrate or move during spraying.

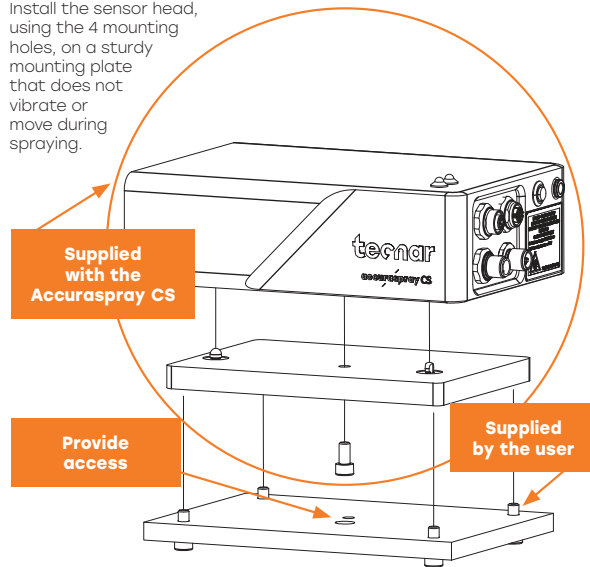

3. Adjusting the sensor head

Connect the compressed air supply and the communication cable to the sensor head. Pull the other end of the communication cable out of the spray booth. Connect the air hose to the booth air supply.

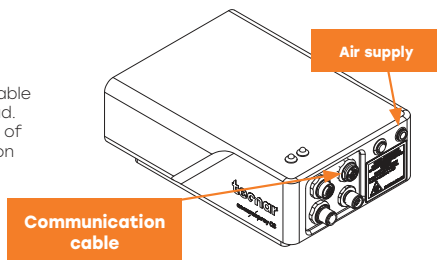

4. Installing the HMI

Install the HMI unit at the chosen location.

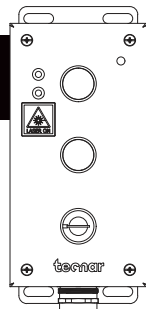

5. Installing the controller

Where to install

Install the controller outside the spray booth.

Installation procedure

Install the Wi-Fi antennas on the controller.

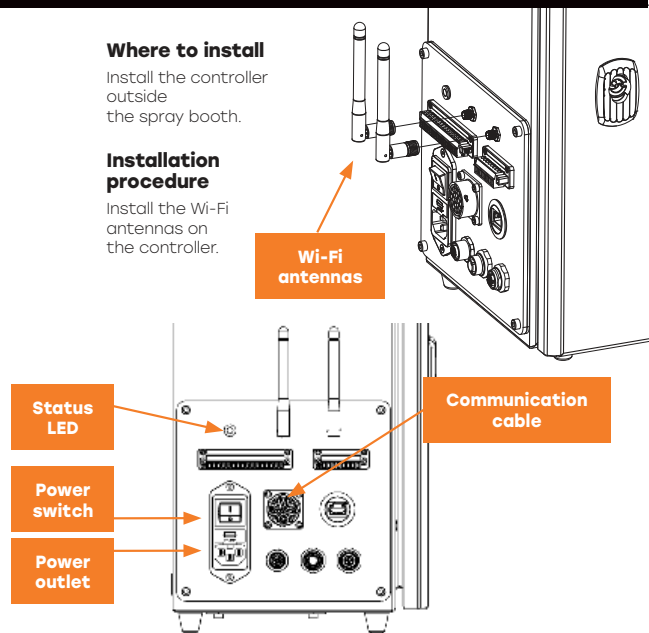

Connect the sensor head communication cable.

Connect the power cable to the controller and plug into a power socket. Flip the Accuraspray controller power switch to ON.

Wait until the status LED turns green.

6. Adjusting the spray gun position

Activate the alignment beam using the push button located at the back of the sensor.

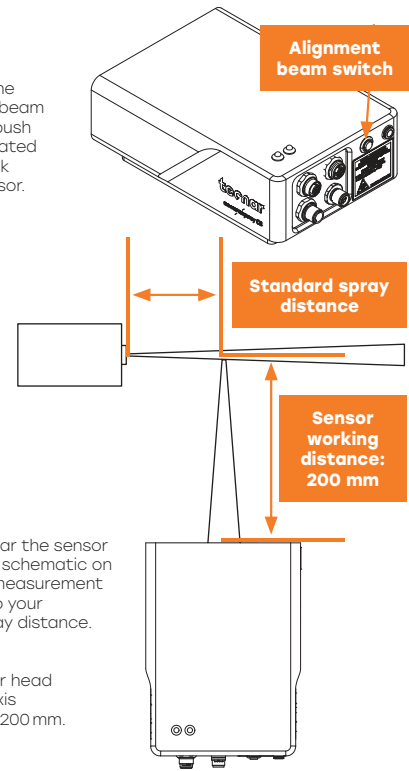

Bring the spray gun near the sensor head as shown on the schematic on the right. The sensor measurement point is normally set to your standard process spray distance.

The distance between the front of the sensor head and the spray torch axis should be adjusted to 200 mm.

7. Accessing the user interface

Accuraspray CS user interface is accessible through a web browser hosted locally on the controller, not available on the internet. We recommend using Google Chrome or Microsoft Edge for optimal performance. Go to the normal Wi-Fi menu on your computer or tablet and look for "Accura CS - serial number". The password to access the Wi-Fi is "accura.wifi".

Open your browser and enter the URL: <http://accuracs-00000000/> to connect to the Accuraspray user interface. Replace the zeros with the serial number of the unit you are trying to connect. The serial number consists of 8 digits which can be found in the Wi-Fi (SSID) network name or under the controller.