

# accuraspray 4.0

## User manual

Online monitoring  
of thermal spray  
processes for the  
shop floor

**tec**nar

our sensors, your productivity.

## NOTICES

© 2023 Tecnar Automation Ltd.

No part of this manual may be reproduced in any form or by any means (including electronic storage and retrieval or translation into a foreign language) without prior agreement and written consent from Tecnar Automation Ltd.

## MANUAL PART

40101-00024-00

The material contained in this document is provided “as is” and is subject to change without notice in future editions.

Revision: November 27<sup>th</sup> 2023

This document contains information considered proprietary and confidential to Tecnar Automation Ltd		
40101-00024-00– Rev J	Revision date: 2023-11-27	Page 2 of 62

## TABLE OF CONTENT

1	SYSTEM DESCRIPTION .....	5
	INTRODUCTION .....	5
	GENERAL PRECAUTIONS.....	6
2	COMPONENTS DESCRIPTION .....	7
	CONTROLLER .....	8
	SENSOR HEAD .....	10
	CABLES, HOSES AND ANTENNAS.....	11
3	SOFTWARE OPERATION .....	12
	3.1. USER INTERFACE OVERVIEW .....	12
	3.2. NAVIGATION TABS .....	13
4.	TECHNICAL SPECIFICATIONS .....	35
5.	INSTALLATION .....	36
	INSTALLING THE SENSOR HEAD .....	36
	5.5. ACCESSING THE USER INTERFACE .....	41
	5.6. SETTING UP THE ACCURASPRAY ON A NETWORK (OPTIONAL).....	42
	5.7. CONNECTING THE I/Os (OPTIONAL).....	42
	5.8. USING THE INPUT TO GENERATE REPORTS .....	42
6.	MAINTENANCE .....	44
	6.1. MAINTENANCE SCHEDULE .....	44
	6.2. MAINTENANCE PROCEDURES .....	45
	RECOMMENDED SPARE PARTS .....	46
7.	TROUBLESHOOTING .....	47
	7.1. LED ERROR CODES.....	47
	7.2. ERROR REPORTING IN THE USER INTERFACE .....	48
	7.3. SERVICE & SUPPORT .....	49
8.	RELATED DOCUMENTS.....	50
APPENDIX A	PLUME ANGLE MEASUREMENT .....	51
	A.1. PHILOSOPHY AND MEASUREMENT PRINCIPLE .....	51
	A.2. HOW THE PLUME ANGLE IS CALCULATED .....	51
APPENDIX B	PROCESS STABILITY .....	54
	B.1. PHILOSOPHY AND MEASUREMENT PRINCIPLE .....	54
	OVERVIEW OF THE STABILITY PANEL .....	55
	THE DISTRIBUTION CHART .....	56
	PERFORMING A STABILITY ANALYSIS IN REAL-TIME .....	60
	THE CALCULATION METHODS .....	61
	ADJUSTING THRESHOLDS BASED ON PREVIOUS RUNS .....	61
	ADJUSTING THRESHOLDS MANUALLY BASED ON MULTIPLE RUNS .....	62

## TABLE OF FIGURES

FIGURE 1 - SCHEMATICAL DESCRIPTION OF THE SYSTEM.....	7
FIGURE 2 - CONTROLLER (FRONT) .....	8
FIGURE 3 - CONTROLLER (BACK) .....	8
FIGURE 4 - SENSOR HEAD (FRONT).....	10
FIGURE 5 - SENSOR HEAD (BACK) .....	10
FIGURE 6 - ACCURASPRAY 4.0 USER INTERFACE .....	12
FIGURE 7 - ACCURASPRAY 4.0 LIVE SCREEN.....	14
FIGURE 8 - RECORDING VIDEO .....	16
FIGURE 9 - VIDEO PLAYBACK .....	17
FIGURE 10 - UPGRADE VIDEO FILE (STEP 1) .....	18
FIGURE 11 - UPGRADE VIDEO FILE (STEP 2) .....	18
FIGURE 12 - ACTIVE GAUGES .....	19
FIGURE 13 – STRIP CHART SCREEN .....	20
FIGURE 14 - PART TEMPERATURE SCREEN .....	21
FIGURE 15 - STRIPCHART BUTTONS BAR .....	22
FIGURE 16 - SAVING PRODUCTION FILE .....	22
FIGURE 17 - PRODUCTION FILES SCREEN.....	23
FIGURE 18 - LOGIN WINDOW.....	24
FIGURE 19 - SETUP SCREEN.....	25
FIGURE 20 - GAUGES PROCESS CONTROL ZONES .....	26
FIGURE 21 - OPENING/DELETING SETUPS.....	27
FIGURE 22 - UNSAVED SETUP MESSAGE.....	27
FIGURE 23 - SAVING SETUPS.....	28
FIGURE 24 - IMPORT/EXPORT SETUPS.....	28
FIGURE 25 - SYSTEM SETTINGS .....	31
FIGURE 26 - REPORT GENERATION MODE .....	32
FIGURE 27 - PLC PLANT INFORMATION .....	33
FIGURE 28 - WINDOWS TIME ZONE EXAMPLE .....	34
FIGURE 29 - UNPACKING THE PARTS .....	36
FIGURE 30 - POSITION OF THE SENSOR HEAD .....	37
FIGURE 31 - SENSOR HEAD MONTING PLATE DIMENSIONS.....	37
FIGURE 32 - MOUNTING THE SENSOR HEAD .....	38
FIGURE 33 - SENSOR HEAD INTERFACE .....	38
FIGURE 34 - CONTROLLER INTERFACE.....	39
FIGURE 35 - CONTROLLER STATUS LED .....	39
FIGURE 36 - SENSOR HEAD ALIGNEMENT BUTTON.....	40
FIGURE 37 - SENSOR HEAD WORKING DISTANCE .....	40
FIGURE 38 - I/O PORTS .....	42
FIGURE 39 - POSITION OF THE 3 LINES USED FOR THE PLUME ANGLE CALCULATION .....	51
FIGURE 40 - PLUME ANGLE AND SAMPLING ANGLE COMPARISON.....	53
FIGURE 41 - STABILITY TOP PANEL.....	55
FIGURE 42 - STABILITY BOTTOM PANEL.....	56
FIGURE 43 - NORMAL DISTRIBUTION.....	57
FIGURE 44 - EXAMPLE USING THE VELOCITY STANDARD DEVIATION.....	58
FIGURE 45 - VELOCITY STABILITY GREEN ZONE AREA COVERAGE .....	59
FIGURE 46 - ADJUSTING THE STABILITY ANALYSIS DURATION .....	60
FIGURE 47 - STABILITY ANALYSIS COMPLETION.....	61

## 1 SYSTEM DESCRIPTION

### INTRODUCTION

The present document gives a complete description and principle of operation of the Accuraspray 4.0 sensor as well as a description of its components.

### OVERVIEW

The main purpose of the Accuraspray 4.0 is to ensure consistent, high-quality coatings by monitoring the in-flight particles and plume properties before each spray run. This ensures that the spray properties are within predetermined acceptance ranges for ideal coating and performance.

To help detect potential issues such as electrode wear, partial clogging of the nozzle or in the powder injection system, and instability of the powder feeder before the coating process, the Accuraspray monitors:

- Particle's temperature and velocity
- Plume profile and intensity
- Plume angle
- Standard deviation of all measurements
- Part temperature (optional)

The Accuraspray 4.0 can also be used to:

- Develop and optimize spray parameters
- Transfer parameters from one booth to another (anywhere in the world)
- Transfer parameters from one spray gun to another
- Extend the useful lifespan of hardware
- Significantly reduce the number of test coupons
- Troubleshoot day-to-day issues



**GENERAL PRECAUTIONS**

The following precautions should be observed at all times while operating the Accuraspray 4.0. Tecnar Automation Ltd. assumes no liability whatsoever for a user’s failure to comply with these precautions or the warnings throughout this manual.

To protect your Accuraspray 4.0 from damage, you must:

- Connect it to an unloaded, properly grounded power line (50–60 Hz. 100-240VAC, 50-60Hz, 1.5 A).
- We also recommend using an additional power line filter to filter out any power surges or bursts.
- Use it at an ambient temperature between 4 and 45 °C.
- Supply 30 LPM (2CFM) of cooling/cleaning air at 1.7–2.7 bar (25–40 psi) to the sensor head AT ALL TIMES while the unit is powered on.
- Use only original spare parts.

All Accuraspray 4.0 users should read this user manual, take the web-based introduction and training sessions, and contact Tecnar with any further questions. We also recommend that a copy of the user manual should always be kept near the equipment.

## 2 COMPONENTS DESCRIPTION

The Accuraspray 4.0 system includes the following elements:

- 1) A sensor head
- 2) A controller
- 3) A substrate pyrometer (optional)
- 4) Air hoses and filter
- 5) Controller power cable
- 6) Sensor head power and communication cable

Each element is described in detail on the following pages.

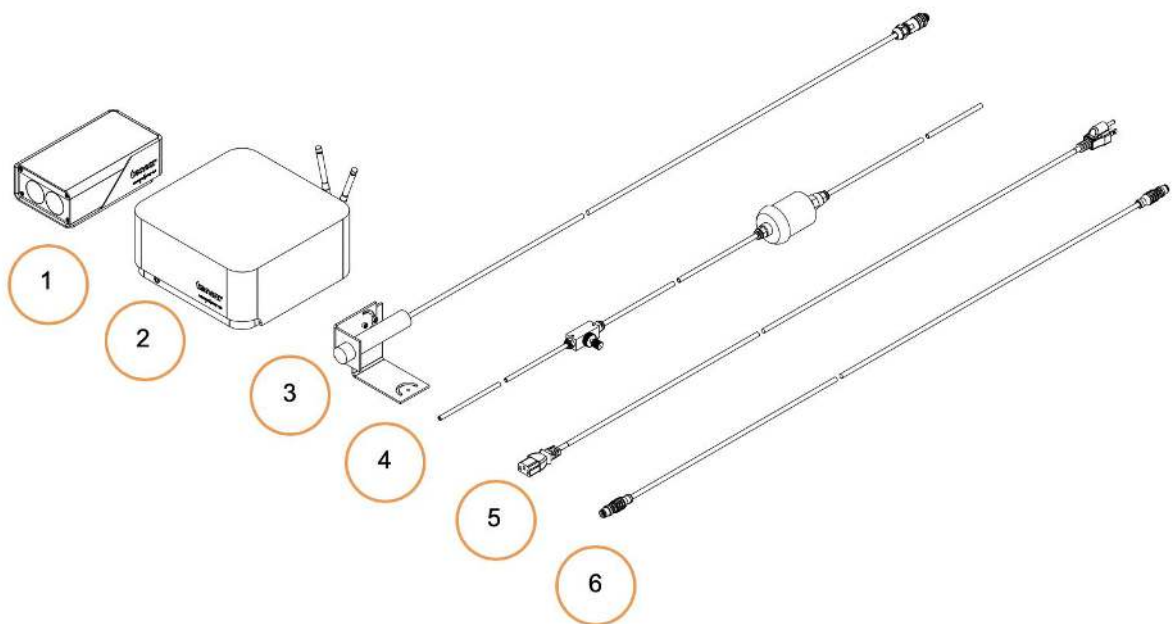

FIGURE 1 - SCHEMATICAL DESCRIPTION OF THE SYSTEM

**CONTROLLER**

The controller must be kept in a ventilated area to reduce the risk of overheating.

The controller receives readings from the sensor head. It processes the data and broadcasts the results to the user interface(s).



FIGURE 2 - CONTROLLER (FRONT)

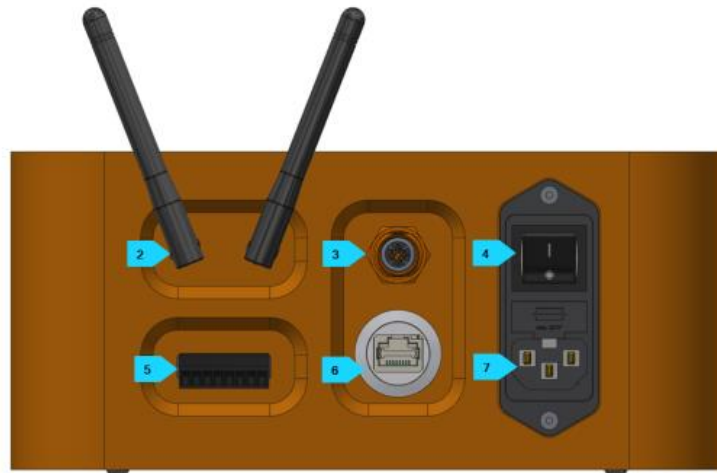
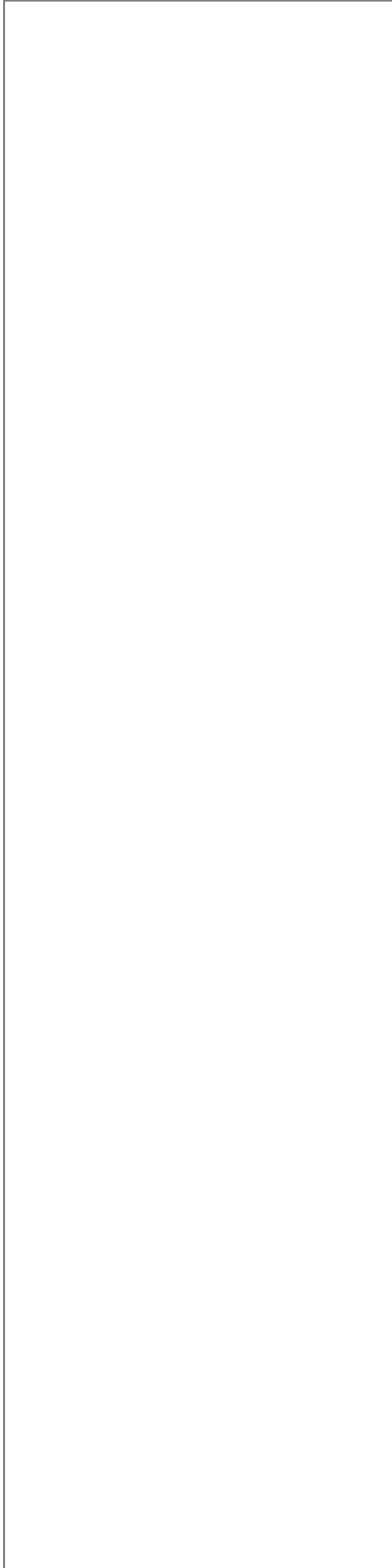

FIGURE 3 - CONTROLLER (BACK)





Component	Description
1. LED	<p>LED</p> <p>Off: Power supply is OFF</p> <p>Green: The system is working properly</p> <p>Yellow: Sensor head is not connected</p> <p>Red: Unit powered up but is in error state.</p>
2. Wi-Fi antennas	<p>Used to access the Accuraspray user interface through a wireless network connection. The Wi-Fi connection acts as a hotspot. It can be disabled but not reconfigured.</p>
3. Sensor head port	<p>Used to power and communicate with the sensor head.</p>
4. Power switch	<p>Used to active the unit.</p>
5. I/O interface	<p>Used to interface the Accuraspray to the user's spray controller via digital I/O ports.</p>
6. Ethernet	<p>Used to access the Accuraspray user interface through a wired network connection (either static or DHCP).</p>
7. Power inlet	<p>Provides power to the Accuraspray.</p> <p><i>Connect it to an unloaded, properly grounded power line (100-240VAC, 50-60Hz, 1.5 A).</i></p>

**SENSOR HEAD**

The sensor head measures the following particles and spray plume properties:

- Particle's velocity
- Particle's temperature
- Spray plume geometry: width, position, angle, and intensity.

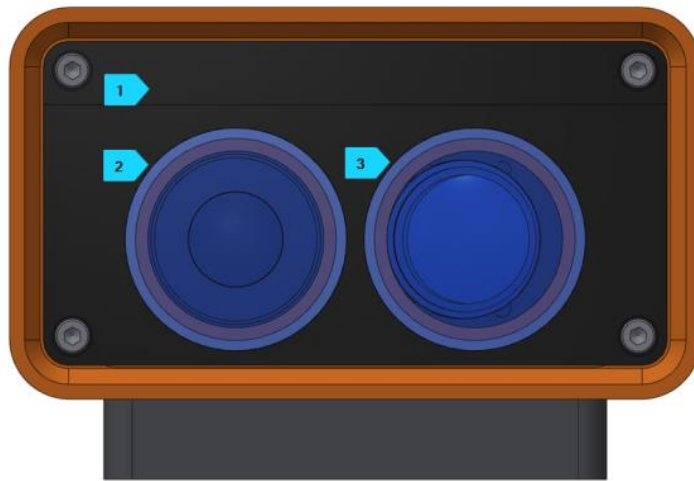

FIGURE 4 - SENSOR HEAD (FRONT)

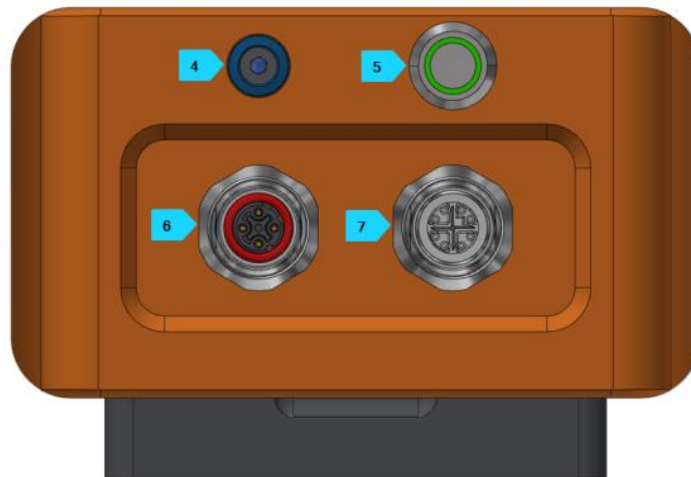

FIGURE 5 - SENSOR HEAD (BACK)

Component	Description
1. Air knife	The air knife is used to keep the Accuraspray windows clean and free of dust.
2. Optical system viewport	Viewport of the temperature and velocity measurement sensor.
3. Camera viewport	Viewport of the camera used to characterize the plume geometry.
4. Air supply port	Compressed air is used both as active cooling for the head's internal components and, as it is exhausted from the head, to generate an air knife that keeps the viewport windows clean.
5. Alignment beam switch	Activation switch for the alignment beam.
6. Substrate pyrometer port	Used to power and communicate with the optional substrate pyrometer sensor.
7. Communication port	Used to power the sensor head and communicate with the controller.

**CABLES, HOSES AND ANTENNAS**

The Accuraspray 4.0 is delivered with several cables, hoses, and antennas, which are described in the following table.

Cables/Hoses/Antennas	Description
IEC power cable	Used to connect the Accuraspray to a power outlet.
Communication cable	Communication between the controller and the measurement head.
Antennas	Used for Wi-Fi communication.
Compressed air hoses	Provide compressed air to the measurement head for cooling and purging purposes. <ul style="list-style-type: none"> <li>• One hose connects the compressed air supply to the air filter</li> <li>• One hose connects the air filter to the pressure regulator</li> <li>• One hose connects the regulator to the measurement head</li> </ul>

### 3 SOFTWARE OPERATION

#### 3.1. USER INTERFACE OVERVIEW

The user interface can be accessed with most internet browsers. Tecnar recommends using Google Chrome or Microsoft Edge (chromium based) browsers. Any modern computer with at least 4GB of RAM should be sufficient to run the user interface smoothly. Connect the PC to the controller via an Ethernet cable or through the built-in Wi-Fi.

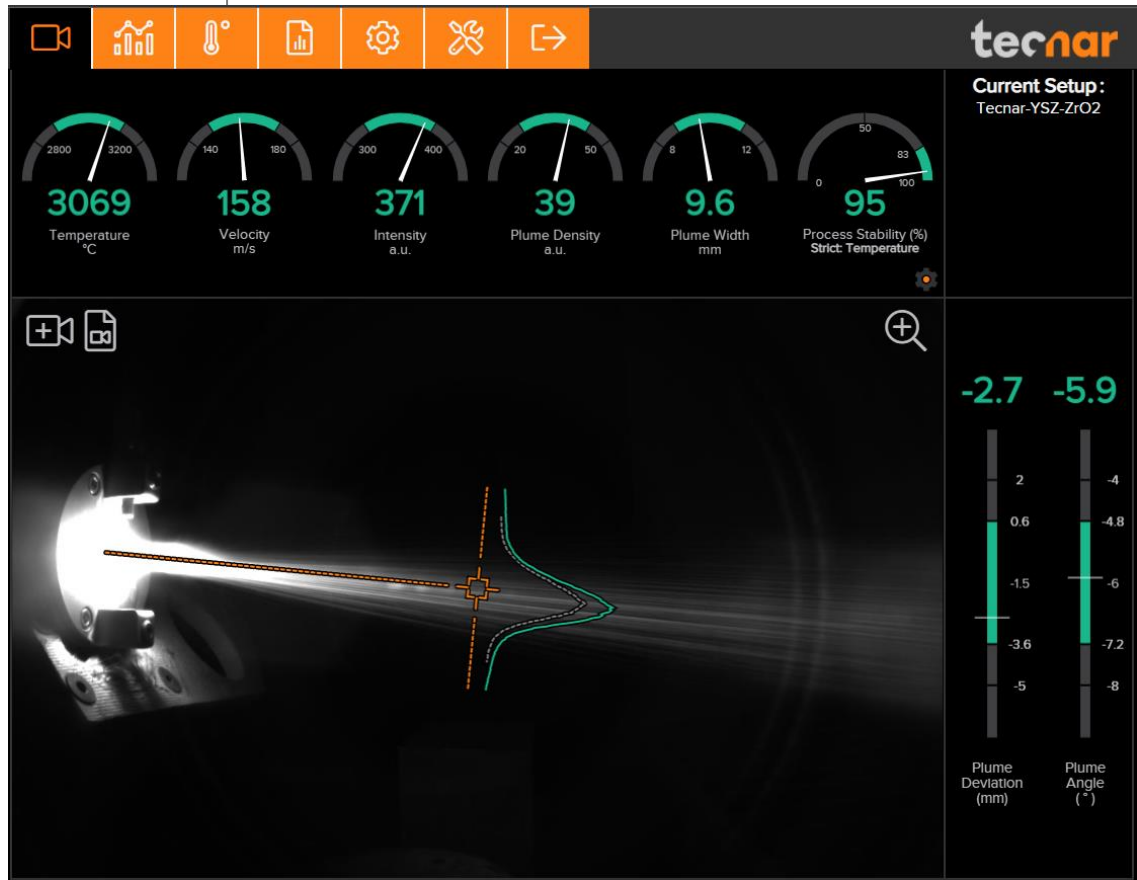











FIGURE 6 - ACCURASPRAY 4.0 USER INTERFACE

### 3.2. NAVIGATION TABS

The navigation icons are displayed at the top of the Accuraspray user interface to access the different tabs. The following table describes those icons.

Icons	Description
	Access the main measurement screen (live).
	Access the strip charts screen.
	Access the part temperature screen.
	Access the production files screen.
	Access the setup screen (spray parameters).
	Access the system settings.
	Take control to gain access to the setup screen.
	Log in.
	Log out.

### 3.3. LIVE SCREEN

The live screen displays in real time all measurements taken by the Accuraspray.

The measurements are displayed at the top and to the right of the screen.

Color codes indicate whether the measurements are within the acceptance range as defined in the setup by the process engineer. A measurement fully within the acceptance range is shown in green, a measurement just barely within the acceptance range is shown in yellow, and a measurement outside the acceptance range is shown in red. Corrective actions should be taken to ensure that all measurements are within the acceptance range and displayed in green.

In the middle of the screen, in the camera view, an orange bullseye represents the position where the particle's temperature and velocity are measured. The distance between the bullseye and the tip of the spray gun, called the standoff distance, is represented by the dotted horizontal orange line. The green curve shows the plume intensity profile as measured by the sensor along the orange vertical line, called the sampling line.

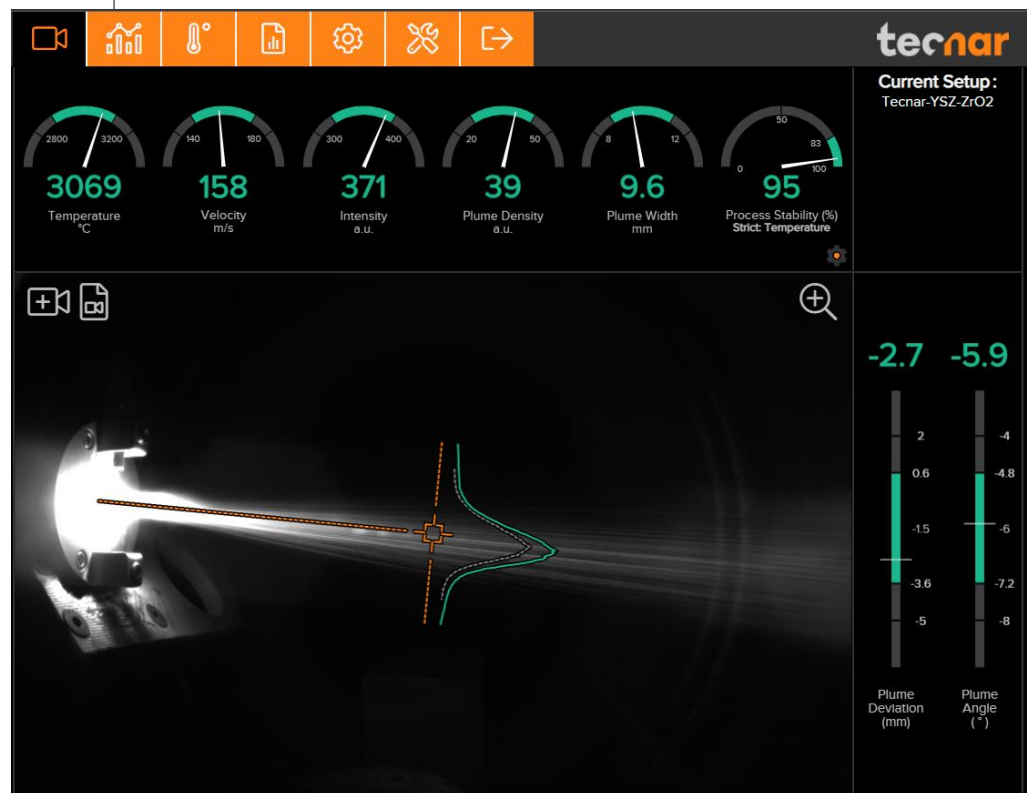

FIGURE 7 - ACCURASPRAY 4.0 LIVE SCREEN

The different measurements provided by the Accuraspray are described in detail in the table below.

Parameters	Description
Temperature	Average particles temperature that are passing through the sensor's measurement volume (bullseye).
Velocity	Average particles speed that are passing through the sensor's measurement volume (bullseye).
Intensity	Intensity of the spray plume. This measurement is very sensitive to minute changes in the spray conditions. The parameters that have the strongest effect on the plume intensity are: <ul style="list-style-type: none"> <li>• Particle's temperature</li> <li>• Average particles diameter</li> <li>• Feedstock emissivity</li> <li>• Feed rate</li> </ul>
Plume density	Provides an indication of the particles flow rate.
Plume width	Width of the spray plume.
Process stability	The stability of the process. This value will vary based on the selected stability mode.
Plume deviation	Deviation of the plume position against the bullseye.
Plume angle	The angle of the particles at the spray distance (bull's eye).
Part temperature	Temperature of the substrate on which the coating is applied. This value is visible in the part temperature window.

### 3.3.1. Zoom in/out

It is possible to zoom in on the center of the image where the bullseye is located.

To do so, click on the magnifying glass icon. This will enlarge the image so that the sampling line, the dotted vertical line overlaid on the camera image, takes 50% of the screen. To return to the full screen click on the magnifying glass again.

This feature is especially useful for HVOF/HVAF where the plume is quite narrow and can be difficult to see when viewing the full camera frame.

The zoom will have no effect if the sampling line length already covers more than 50% of the screen height.

### 3.3.2. Recording a video sequence

Sequences can be recorded and replayed using the icons at the top left corner of the video panel. The camera icon is used to start recording. A minimum of 5 seconds must be recorded before clicking the “Stop Recording” button.

Once the Accuraspray is recording, the camera button will start blinking red.

To stop recording, click on the square icon next to the camera. This will automatically download the sequence to your computer in your web browser’s default download directory. Simultaneously, the controller will also save and generate a report (.pdf + .csv) that will be stored in the controller. The loading overlay will appear during that time, indicating “Saving Report in the Controller”.

Recorded video sequences (.video files) are not stored on the Accuraspray Controller. Lastly, it is not possible to start recording a sequence when the setup is unsaved. This is intended to avoid confusions and discrepancies with the active setup.

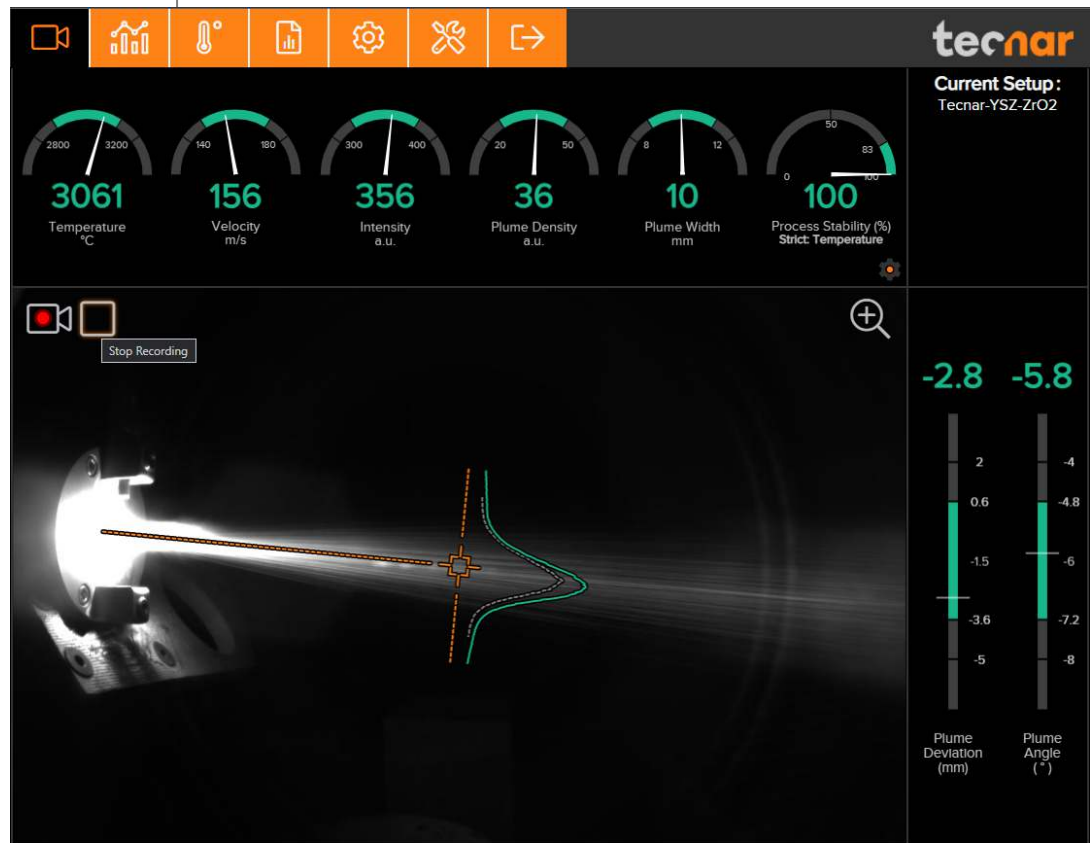

FIGURE 8 - RECORDING VIDEO



### 3.3.3. Replaying a video sequence

To open and start replaying a saved sequence, click on the camera folder icon next to the recording button, and select the sequence that you want to replay.

As mentioned previously, the video sequences are not stored on the Accuraspray controller. You will find them on your computer in your default download directory or wherever you have stored them.

When replaying a sequence, the “Stop Video” icon will appear. Use it to exit replaying mode and go back to live mode.

It is possible to pause a sequence using the “Pause” icon and resume playback using the “Play” icon. You can also switch from the live screen to the strip chart screen to view the plots in real-time.

The name of the video file appears at the bottom left, and the elapsed time at the bottom right as seen in the picture below.

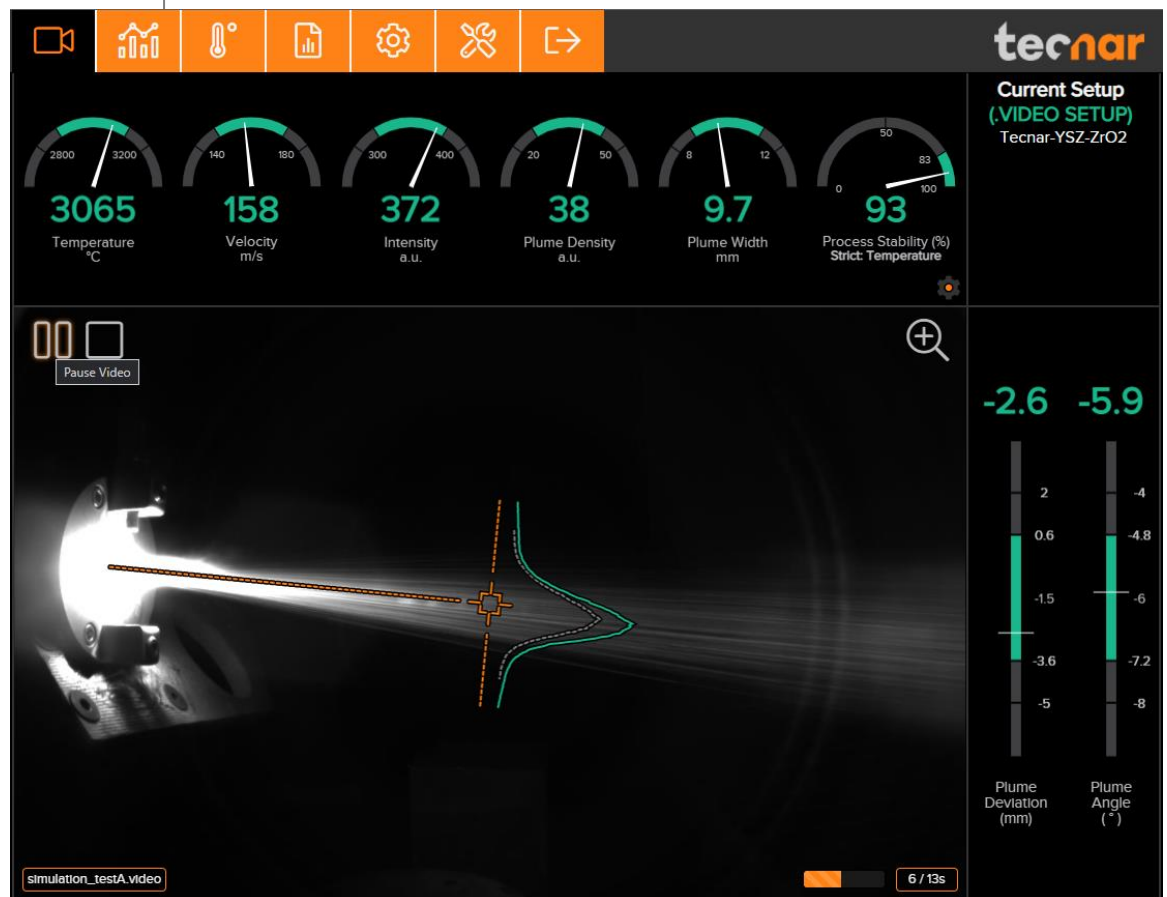

FIGURE 9 - VIDEO PLAYBACK

In video mode, the setup parameters will reflect the ones that were active at the time of the recording.

### 3.3.4. Upgrading a video sequence

Videos files that were recorded prior to version 1.4.1 did not have an embedded setup, causing discrepancies between the setup that was used at the time of recording and the current setup of the system. In that case, the video is played “as is”. The gauges min/max settings, projection overlay, and other setup settings do not reflect the reality. To get rid of this problem, new video files now include the setup within the video file itself. Furthermore, you can now upgrade your old video files and link the proper setup that was used at the time. You will be prompted to download a new video file (‘--with-setup’). Link the proper setup by choosing from the setup list as shown below. You can safely delete your old video file that does not include the setup afterwards. This additional step is not mandatory.

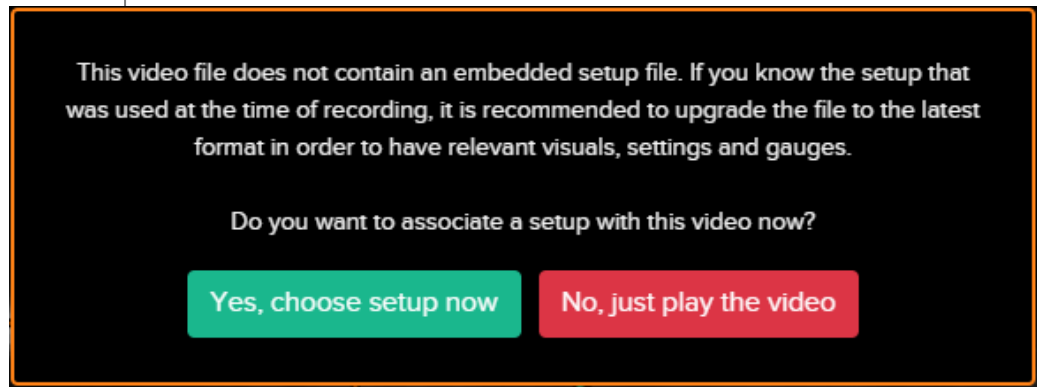

FIGURE 10 - UPGRADE VIDEO FILE (STEP 1)

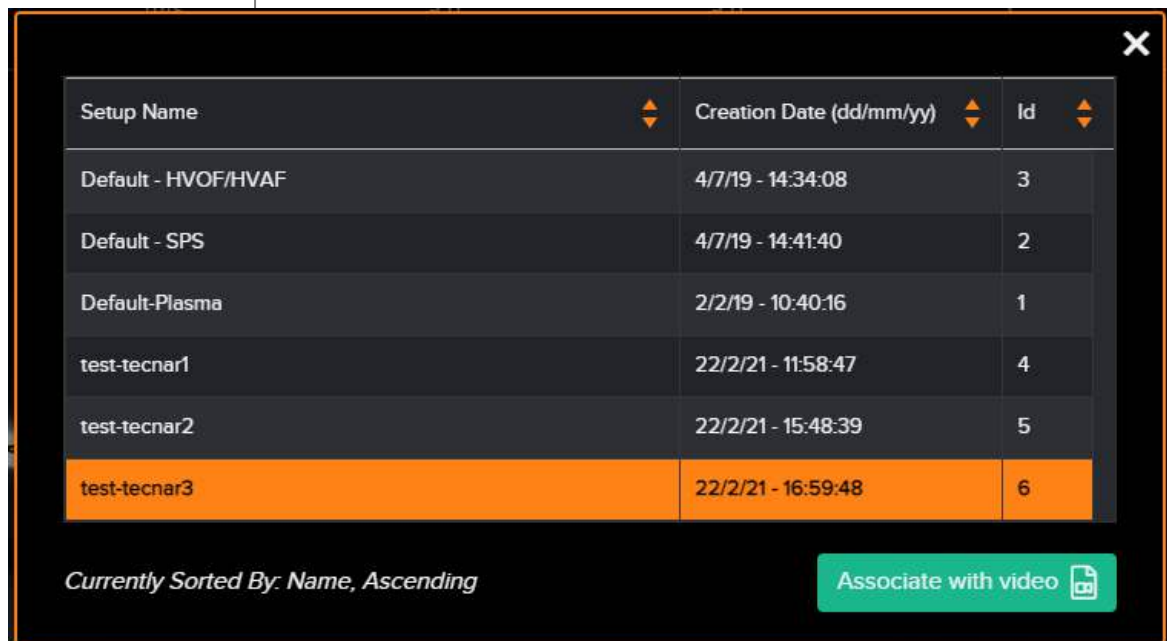

FIGURE 11 - UPGRADE VIDEO FILE (STEP 2)

### 3.3.5. Selecting active gauges

Starting from version 1.7.0, it is now possible to select active gauges for the measurement status. Inactive gauges will NOT be considered for the measurement status (output state). In some cases, you may want to focus on certain measurements, since other measurements may be less relevant to you based on your process and application. In that case, “uncheck” the gauges that you wish to deactivate. Inactive gauges will not show up in the live screen, nor the strip charts tab. However, the data for these measurements will still appear in the strip charts when you save a production report.

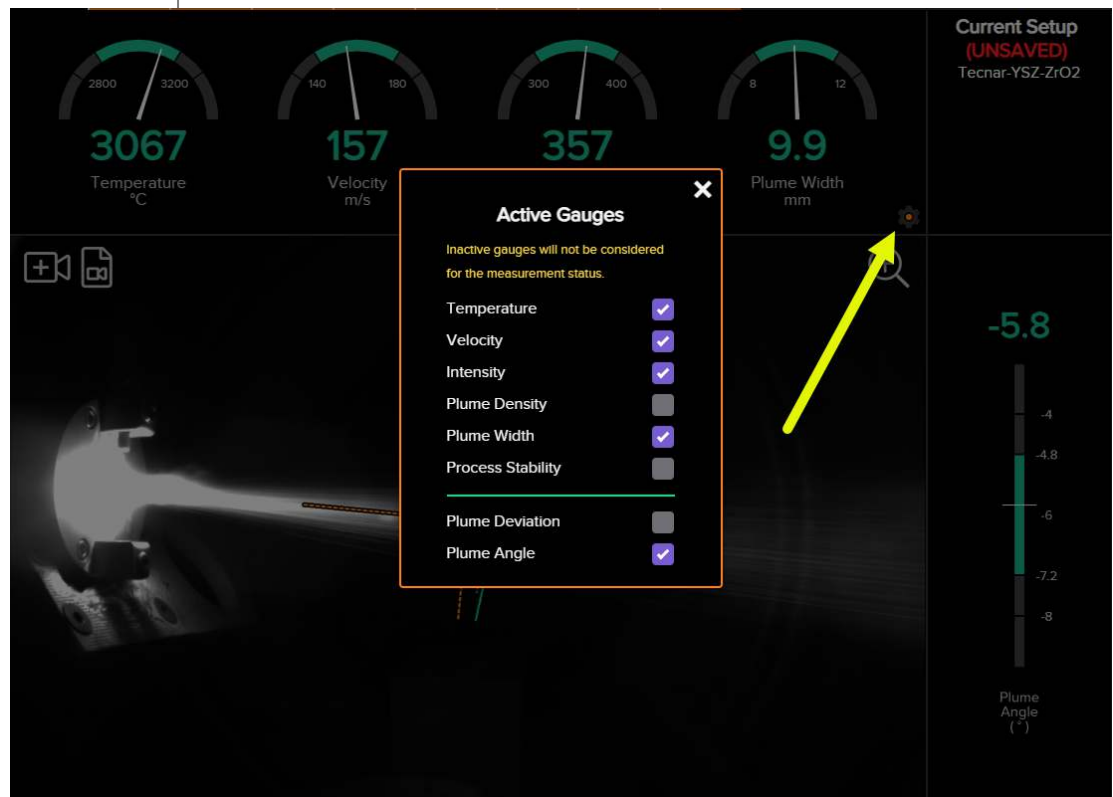

FIGURE 12 - ACTIVE GAUGES

Clicking on the cogwheel button will spawn the “Active Gauges” menu. This button is also duplicated in the settings tab along with the other spray parameters.

### 3.4. STRIP CHART SCREEN

The strip chart screen displays the evolution over time of measurements available on the live screen.

In the middle of the screen, you will find two graphs, each displaying one type of measurement. It is possible to select which measurement to display from the table located to the right of the graphs.



FIGURE 13 – STRIP CHART SCREEN

### 3.4.1. Adjusting the time span

The time duration displayed on the strip charts can be adjusted using the number input at the top left of the page. The charts can display up to 24 hours of measurements. The default value is 5 minutes. The minimum time span is 0.5 minute (30 seconds), and the maximum is 24 hours (1440 minutes).

The last 24 hours are stored in the database and can be recalled at any time.

### 3.4.2. Adjusting the Y-axis display

The range of the strip charts Y-axis can be adjusted in two ways:

- Fixed: sets the Y-axis limits (min and max values) according to the acceptance ranges as defined in the setup.
- Auto: sets the Y-axis limits (min and max values) according to the full scale of the values captured by the sensor.

### 3.5. PART TEMPERATURE SCREEN

The part temperature, also known as the substrate temperature, has been moved from the live screen to its own separate tab. The reason for this is mainly because the part temperature is measured during the spraying operation.

When you change the min/max settings in this tab, make sure to go back to the settings tab and save your changes.

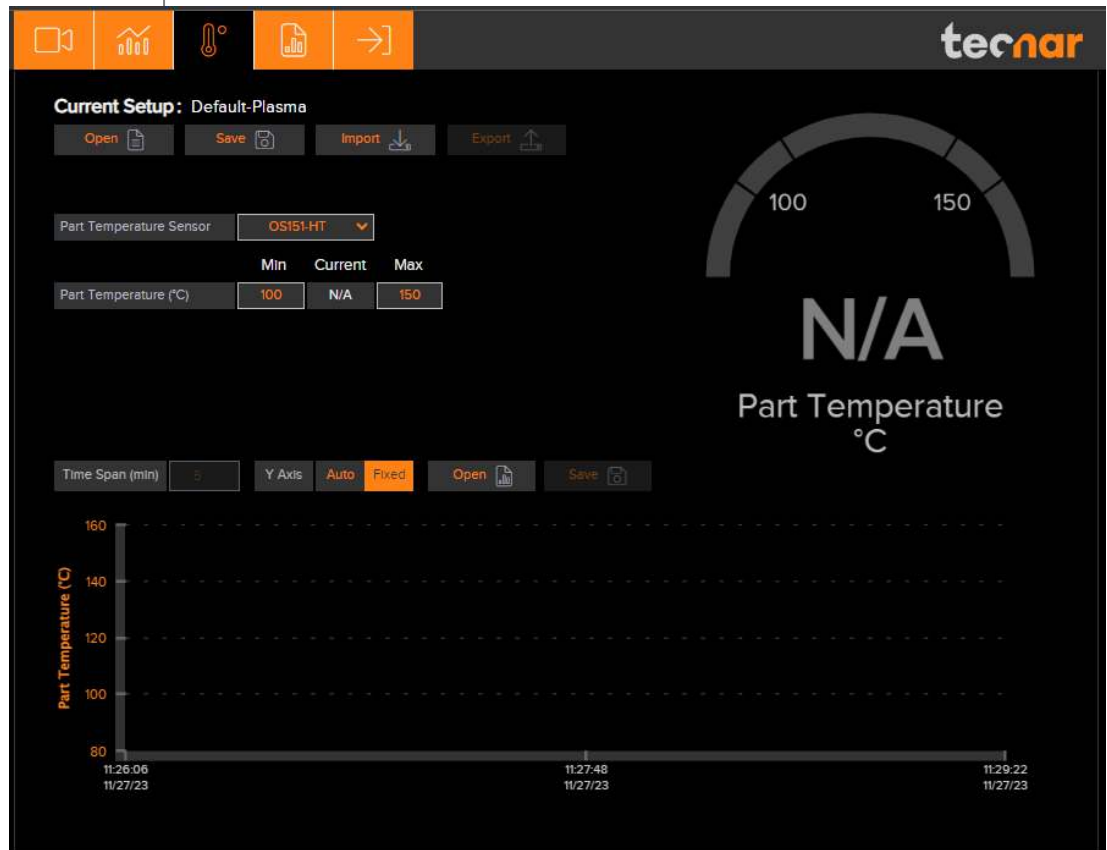

FIGURE 14 - PART TEMPERATURE SCREEN

### 3.6. PRODUCTION REPORTS

Production reports can be generated from the strip chart screen, the live screen, and through the IO module. When clicking the “Save” button, the data contained in the strip charts and a screenshot of the camera screen will be copied into a .pdf and .csv file. Setting a time span of 1 minute will generate a report that contains the last minute of data. Thorough analysis of the spray parameters can be found in the production report (.pdf). Recording a video file will also trigger a report generation. The name of the report will match the name of the video file.



FIGURE 15 - STRIPCHART BUTTONS BAR

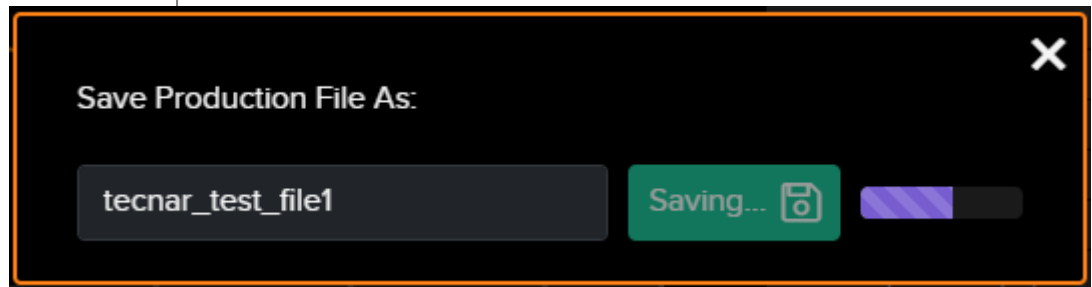

FIGURE 16 - SAVING PRODUCTION FILE

The production reports are stored on the Accuraspray controller’s hard drive. The directory where the files are stored is accessible by clicking on the “Open” button. It also contains all the strip charts (.csv files). The duration of the strip charts in the production report is the same as the value in the user interface when the production report was generated. Clicking the “Open” button will redirect the user to the production files screen, directly in the folder of the last generated file. If desired, you can also use the raw .csv data and generate your own plots. Here is an example of the production files screen:

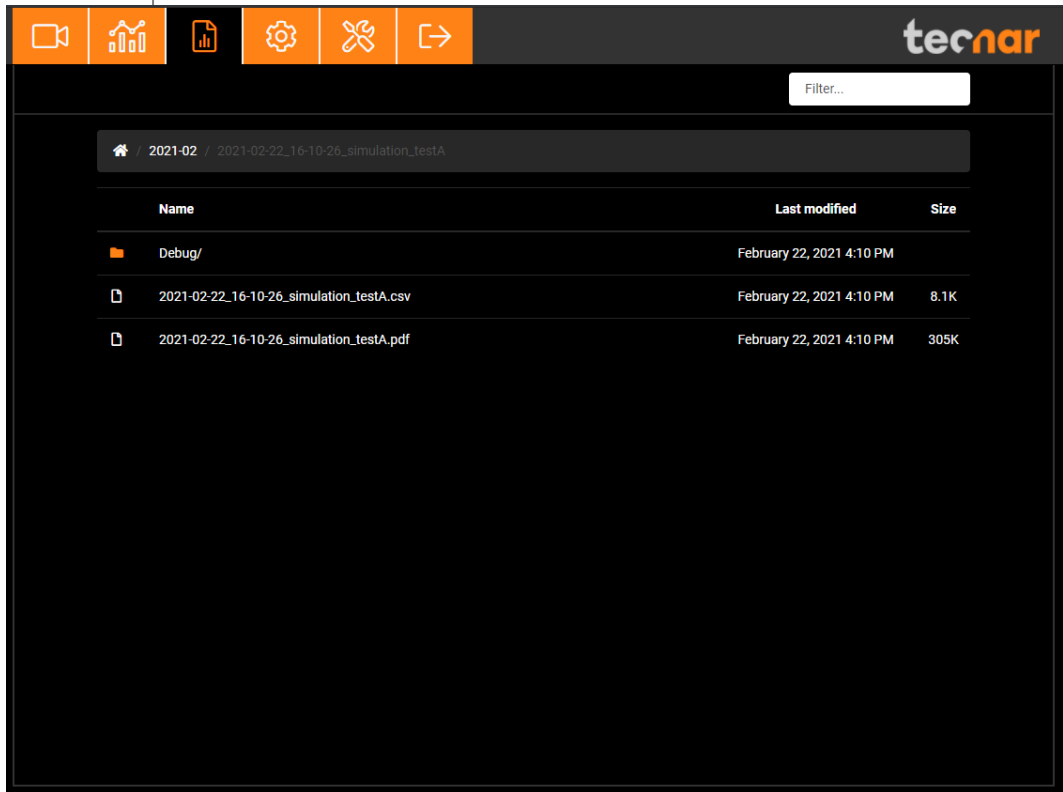

FIGURE 17 - PRODUCTION FILES SCREEN

### 3.7. LOGGING IN

The Accuraspray’s interface allows multiple, simultaneous users (up to 5). For instance:

- One user or “the operator” can be using the system for measurement (will need to “take control” as covered in subsequent sections).
- Another user can be “watching” the “operator” from the engineering office via the network or wireless.
- Another user can be viewing saved files from previous runs in the QC department.

When accessing the Accuraspray interface, users that are not logged in are in viewer mode and can only visualize the sensor’s readings from the live screen or the strip charts screen.

To make changes to the setup and record sequences it is necessary to log in by clicking the designated icon. Users can log in either as operator or administrator.

- Operators (**username: operator**) can change (load) the setup used by the sensor and record measurement sequences. Operators cannot modify setups. The default password for operators is: **accura.operator**
- Administrators (**username: admin**) have the same rights as the operators and can also create, modify, and delete setups. The default password for administrator is: **accura.admin**

Users' passwords can be changed in the settings tab.



To log in, click  to display the login window and enter your credentials as shown below:

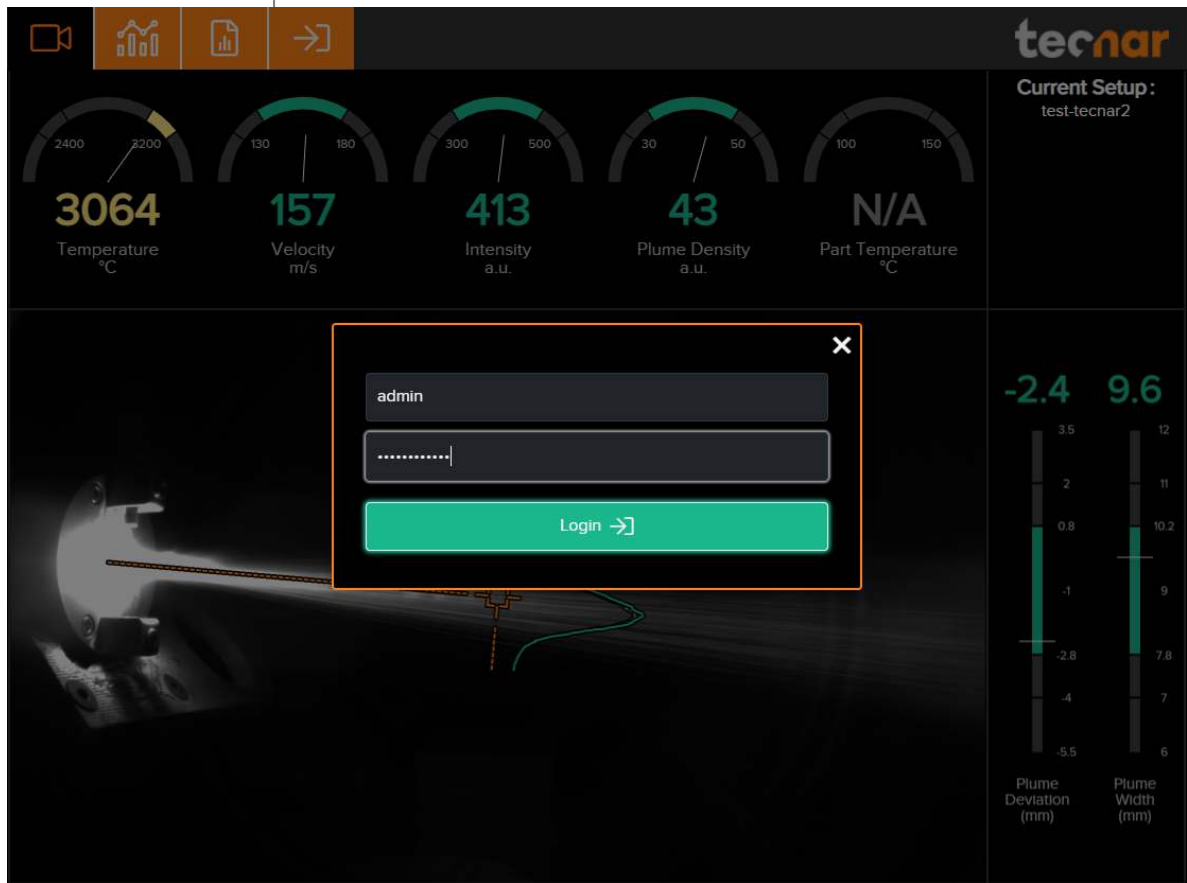

FIGURE 18 - LOGIN WINDOW



### 3.8. SETUP SCREEN (OPERATOR AND ADMINISTRATOR ONLY)

The setup screen is where the sensor's parameters are managed. Click the



gear icon to access the setup screen.

Data Acquisition Parameters		Min/Max		Stability		Min	Current	Max
Process Type	Plasma	Signal Amplification	26%	2	Temperature (°C)	2800	3061	3200
Spray Direction	→	Exposure Time (µs)	40%	1600	Velocity (m/s)	140	157	180
Standoff Distance (mm)	62	Execute Autoset			Intensity (a.u.)	300	372.4	400
Sampling Line Length (mm)	70	Set Plume Profile Reference			Plume Density (a.u.)	20	38.5	50
Sampling Angle (°)	-5.5	Select Active Gauges			Plume Width (mm)	8	9.7	12
Reaction Time (s)	5				Plume Deviation (mm)	-5	-2.6	2
					Plume Angle (°)	-8	-5.9	-4

FIGURE 19 - SETUP SCREEN

### 3.8.1. Min/max adjustments

The left side of the setup screen shows the data acquisition parameters for the current process. Under “Current Setup”, the setup control bar allows users to open/delete, save, import, and export setups.

The right side of the configuration screen shows the acceptance ranges, when the “min/max” menu is selected. These min and max values represent the values past which the process is considered off (red zone). The range between those values contains the green and yellow zones. The green value represents 60% of the full range between the min and max while the yellow regions warn the operators that the measurement is leaning towards the red zone. The yellow zones represent 20% of the total span, starting from the lower and upper thresholds, as shown in the picture below:

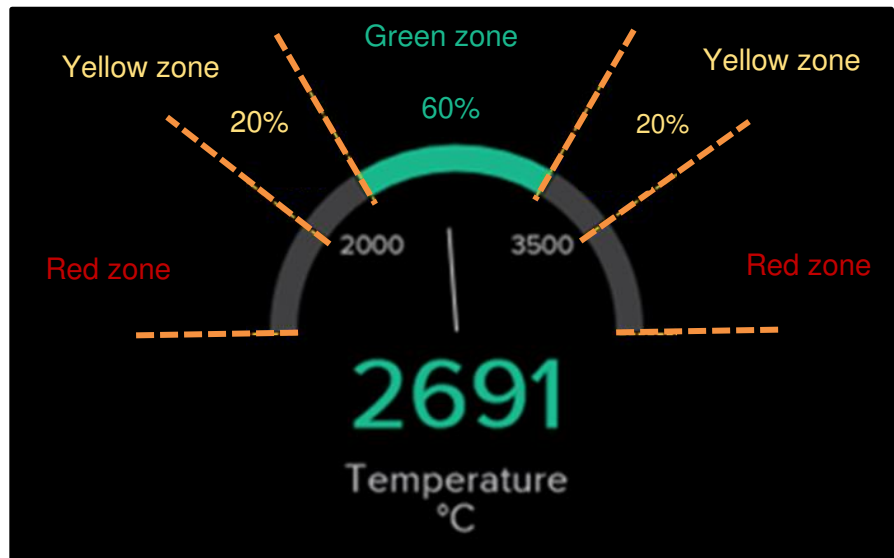
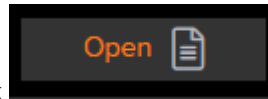

FIGURE 20 - GAUGES PROCESS CONTROL ZONES

The red zones cover all other values. In other words, the values below the minimum threshold, and above the maximum threshold will be considered red.

### 3.8.2. Opening/Deleting setups



In the setup screen, click . This will open the list of setups.

To load a setup, select the setup and click “Open”. The new setup is automatically applied. To delete a setup, click the “Delete” button. A confirmation message will appear. You will notice that the default setups cannot be deleted.

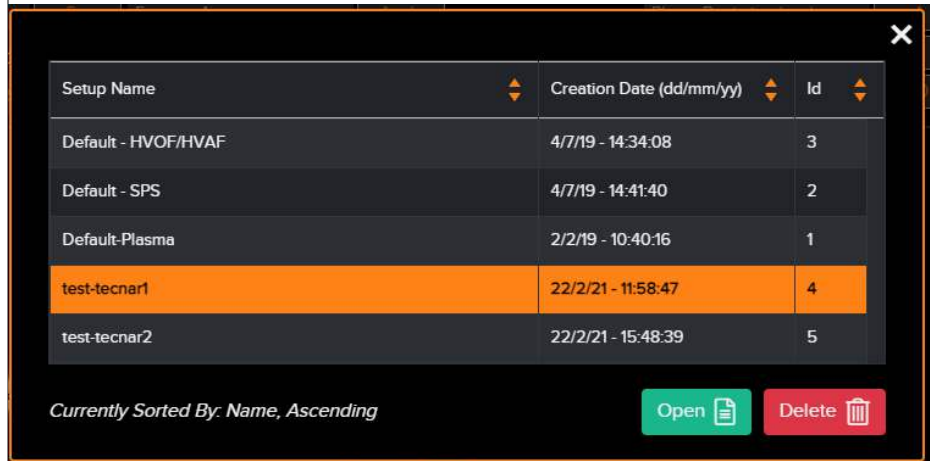

FIGURE 21 - OPENING/DELETING SETUPS

### 3.8.3. Saving setups

Upon modifying any parameter in the setup screen, you can save the modifications as a new setup or overwrite the existing setup. Whenever you have pending changes in the current setup, the “UNSAVED” message will appear. It will appear either in the top right corner or above the setup name, depending on the current tab.

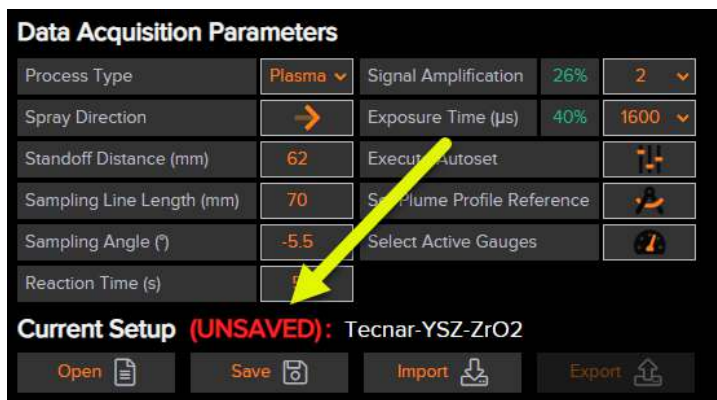

FIGURE 22 - UNSAVED SETUP MESSAGE

In the setup screen, click . This displays the following window.

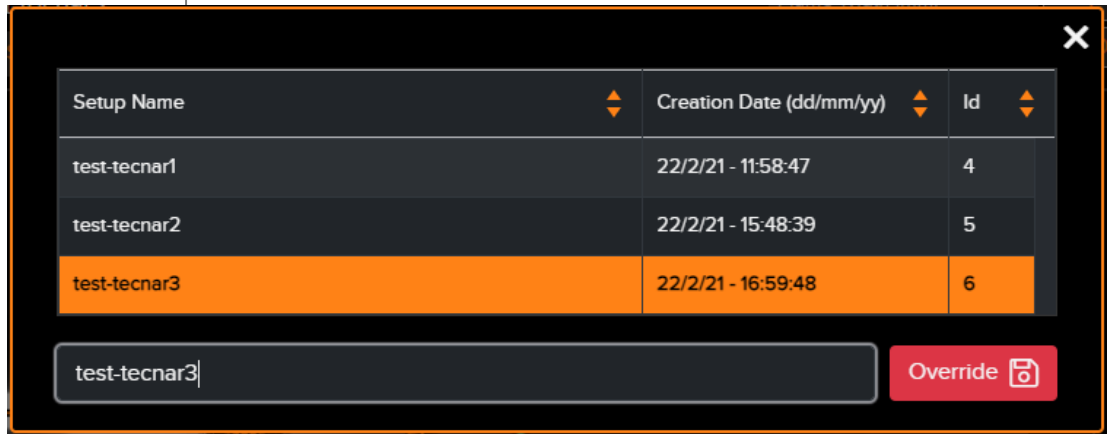

FIGURE 23 - SAVING SETUPS

To overwrite a setup, select a setup and click “Override”. The new parameters are automatically saved.

To add a new setup, enter a new setup name and click “Save”.

### 3.8.4. Importing and exporting setups

Setups can be exported from one Accuraspray unit and imported into another. When clicking on the “Export” button a setup file with the “.setup” extension will be downloaded on your computer.

To import a setup, simply click on the “Import” button and select the setup file that you wish to import from your computer.

This functionality ensures that multiple sensors are using the same settings in a production environment. This is especially useful when comparing two booths using the same hardware and have two different Accuraspray units.

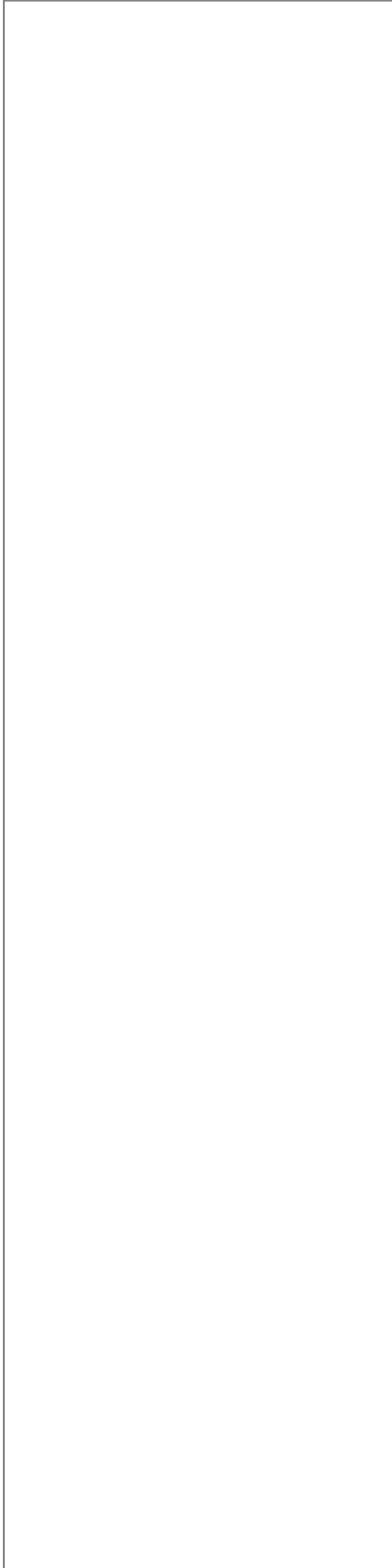

FIGURE 24 - IMPORT/EXPORT SETUPS

### 3.8.5. Setup parameters

The table below explains the data acquisition parameters that are used to configure the Accuraspray according to the spray process you will be monitoring.

Parameters	Description
Process type	This value indicates to the sensor if the process brightness is high or low. Typically, SPS, Arc spray and SSPS are considered high brightness processes while HVOF and HVAF are considered low brightness. Changing this value will adjust the optical channels.
Spray direction	Particle's travel direction (left to right or right to left) relative to the Accuraspray field of view.
Standoff distance	Distance between the Accuraspray measurement point (bullseye) and the spray gun output. Typically, it is the process spray distance.
Sampling line length	This value determines the length, in the plane of the plume, of the path along which the intensity profile is measured. It is normally set to about four times the regular plume width.
Sampling angle	This value tilts the sampling line so that it lays perpendicular to the general direction of the particle flow (typically -5° for top injected plasma spraying and 0° for HVOF spraying).
Reaction Time	Length of the moving average used by the sensor to display measurements. This parameter is used to smooth out natural variations in the process that would make the sensor's reading unstable and unusable for process control.  Typical reaction time for APS and Wire arc is 5 to 15 seconds. For HVOF/HVAF, values between 1 to 5 seconds are usually preferred.
Signal amplification	This value needs to be increased until signal level reaches roughly 35% (the percentage value next to the amplification level is the signal level). This is the scope signal level.  In general, the auto-set feature will take care of this adjustment for you.
Exposure time	This value needs to be increased until signal level reaches roughly 50% (the percentage value next to the amplification level is the signal level). This is the camera signal level. Note that the "optimal" camera signal level differs from the scope signal level.  In general, the auto-set feature will take care of this adjustment for you.



Execute Autoset	<p>This feature automatically adjusts the “exposure time” for the camera measurements and the “signal amplification” for scope measurements.</p> <p>These settings can also be modified manually using their respective drop-down selectors.</p> <p>However, before an auto-set can be performed, the spray plume must be centered on the bullseye and the following data acquisition parameters must be set properly:</p> <ul style="list-style-type: none"> <li>• Process type</li> <li>• Spray direction</li> <li>• Standoff distance</li> <li>• Sampling line length</li> </ul>
Set Plume Profile Reference	<p>By clicking this button, the user captures the current plume profile and sets it as the reference for future measurement.</p>
Select Active Gauges	<p>When clicking this button, a pop-up menu will appear, allowing the user to activate or deactivate specific gauges. This button is the same as the “cogwheel” button in the live screen.</p>
Min/Max Thresholds	<p>The lower and upper limits for each measurement type.</p>
Stability Thresholds	<p>Just like the min/max thresholds, the stability thresholds are applied to every measurement type (except for the part temperature). Each measurement type is comprised of 3 thresholds:</p> <ul style="list-style-type: none"> <li>- Standard Deviation Reference</li> <li>- Standard Deviation Yellow Threshold</li> <li>- Standard Deviation Red Threshold</li> </ul>
Stability Calculation Method	<p>The stability calculation method is either strict or average. Refer to the <a href="#">stability section</a> for additional details.</p>

Changing ANY of these parameters will affect the current setup. Please make sure that you save your changes by clicking the “Save” button.

### 3.9. SYSTEM SETTINGS

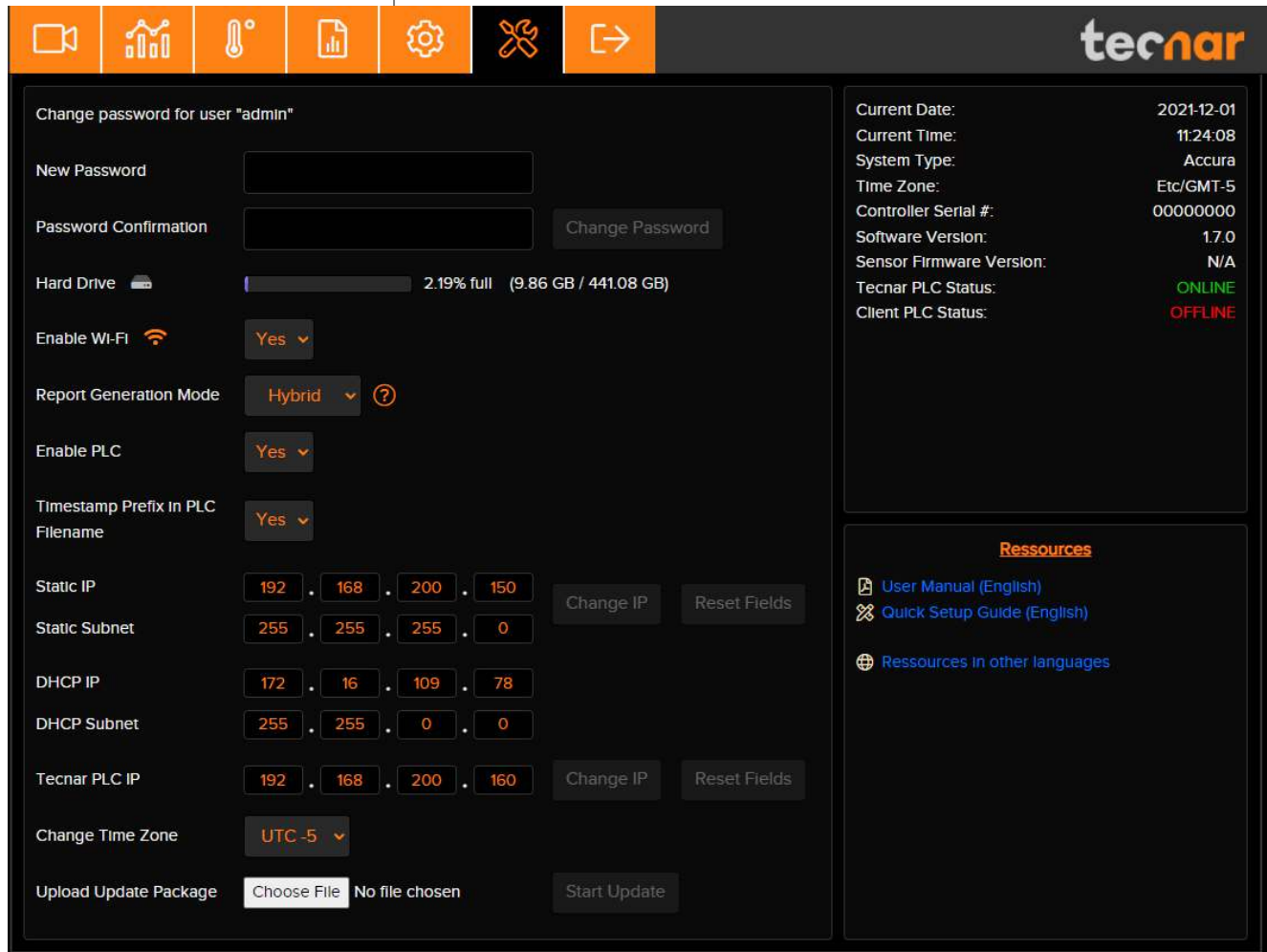

FIGURE 25 - SYSTEM SETTINGS

#### 3.9.1. Changing the user password

Enter a new password and click ‘Change Password’ to modify it.

Note that you will have to login either as Operator or Administrator to access the settings screen.

#### 3.9.2. Enabling/Disabling Wi-Fi

Users may choose to enable or disable the built-in Wi-Fi for security purposes. A reboot is not necessary, but it will take a few seconds for the change to take effect.

### 3.9.3. Report Generation Mode

This option has been added in order to avoid unintended, simultaneous requests to generate reports. In addition, it can be used to narrow down the scope of report generation actions. For example, if you always generate reports using the IO module, you may want to set this option to “Hardware Mode”. By doing so, users will not be able to trigger reports within the UI, avoiding duplicate requests. There are 3 different modes:

- Hardware Mode: the controller will listen to input events from the IO module exclusively. Generating reports and videos from the UI is disabled.
- Software Mode: the controller will ignore input events from the IO module. Generating reports and videos from the UI is enabled.
- Hybrid Mode: the user can generate reports from the IO module and the UI. A warning message will appear in the UI when already recording from the IO module, and IO events will be ignored when the user is already recording from the UI.

The default mode is “Hybrid”. In the vast majority cases, it can be left as is.

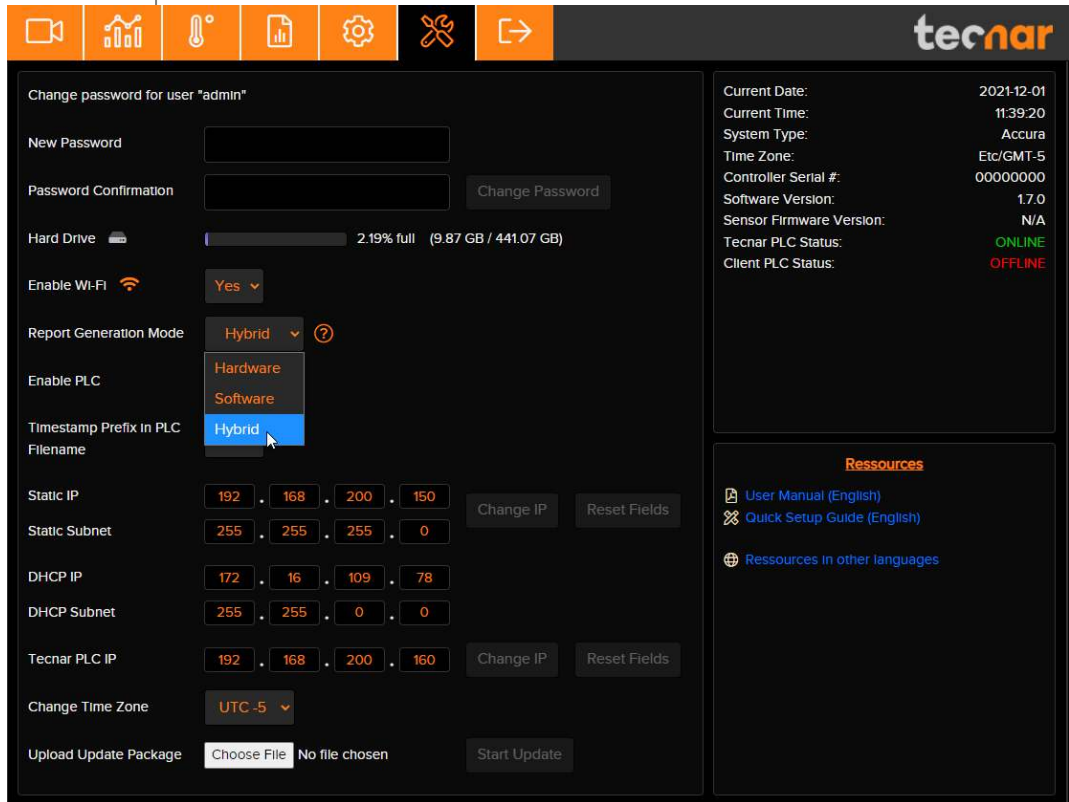

FIGURE 26 - REPORT GENERATION MODE



### 3.9.4. Enabling/Disabling the PLC

The PLC is an optional feature that provides a deeper level of integration for customers who wish to make use of the Accuraspray’s functionalities without necessarily having to go through the User Interface. The Accuraspray can stream data through a PLC Profinet interface. Contact Tecnar at [sales@tecna.com](mailto:sales@tecna.com) for more details if you wish to obtain more details regarding this bundle. Implementation details for this feature can be found in the [PLC documentation](#).

### 3.9.5. Timestamp Prefix in PLC filename

This option lets users override the automatically generated timestamp with your own locally generated timestamp. This can sometimes avoid mismatches between your PLC and the Accuraspray timestamps. When activating this option, make sure that you include your own timestamp in the PLC’s “ReportFileName” tag.

SOFT_READ_PLANT_INFO							
	Name	Data type	Offset	Start value	Retain	Accessible ...	Writa... Visibl...
1	Static				<input type="checkbox"/>	<input type="checkbox"/>	<input type="checkbox"/>
2	PlantInfo	"TecnarPlantInf..."	0.0		<input type="checkbox"/>	<input checked="" type="checkbox"/>	<input checked="" type="checkbox"/>
3	ReportFileName	Array[0..59] of Char	0.0		<input type="checkbox"/>	<input checked="" type="checkbox"/>	<input checked="" type="checkbox"/>
4	Label1	"TecnarReportLabel"	60.0		<input type="checkbox"/>	<input checked="" type="checkbox"/>	<input checked="" type="checkbox"/>
5	Label2	"TecnarReportLabel"	110.0		<input type="checkbox"/>	<input checked="" type="checkbox"/>	<input checked="" type="checkbox"/>
6	Label3	"TecnarReportLabel"	160.0		<input type="checkbox"/>	<input checked="" type="checkbox"/>	<input checked="" type="checkbox"/>
7	Label4	"TecnarReportLabel"	210.0		<input type="checkbox"/>	<input checked="" type="checkbox"/>	<input checked="" type="checkbox"/>
8	Label5	"TecnarReportLabel"	260.0		<input type="checkbox"/>	<input checked="" type="checkbox"/>	<input checked="" type="checkbox"/>
9	Label6	"TecnarReportLabel"	310.0		<input type="checkbox"/>	<input checked="" type="checkbox"/>	<input checked="" type="checkbox"/>
10	Label7	"TecnarReportLabel"	360.0		<input type="checkbox"/>	<input checked="" type="checkbox"/>	<input checked="" type="checkbox"/>
11	Label8	"TecnarReportLabel"	410.0		<input type="checkbox"/>	<input checked="" type="checkbox"/>	<input checked="" type="checkbox"/>
12	Label9	"TecnarReportLabel"	460.0		<input type="checkbox"/>	<input checked="" type="checkbox"/>	<input checked="" type="checkbox"/>
13	Label10	"TecnarReportLabel"	510.0		<input type="checkbox"/>	<input checked="" type="checkbox"/>	<input checked="" type="checkbox"/>
14	Label11	"TecnarReportLabel"	560.0		<input type="checkbox"/>	<input checked="" type="checkbox"/>	<input checked="" type="checkbox"/>
15	Label12	"TecnarReportLabel"	610.0		<input type="checkbox"/>	<input checked="" type="checkbox"/>	<input checked="" type="checkbox"/>
16	Label13	"TecnarReportLabel"	660.0		<input type="checkbox"/>	<input checked="" type="checkbox"/>	<input checked="" type="checkbox"/>
17	Label14	"TecnarReportLabel"	710.0		<input type="checkbox"/>	<input checked="" type="checkbox"/>	<input checked="" type="checkbox"/>
18	Label15	"TecnarReportLabel"	760.0		<input type="checkbox"/>	<input checked="" type="checkbox"/>	<input checked="" type="checkbox"/>
19	Label16	"TecnarReportLabel"	810.0		<input type="checkbox"/>	<input checked="" type="checkbox"/>	<input checked="" type="checkbox"/>
20	FutureBytes	Array[0..1023] of B...	860.0		<input type="checkbox"/>	<input checked="" type="checkbox"/>	<input checked="" type="checkbox"/>

FIGURE 27 - PLC PLANT INFORMATION

### 3.9.6. Changing the static IP of the controller

It is possible to change the IP of the controller to match your desired static network. Simply click the “Change IP” button. Keep in mind that you will need to adjust your “/etc/host” interface file to be able to access the controller using its “hostname”. This is important to make sure that all the features work correctly in the UI, such as the production file tab. A reboot is required for this operation. Refer to the document [“Accuraspray 4.0 Network Connections”](#) for in-dept details.

### 3.9.7. DHCP IP

The Accuraspray has only one physical ethernet interface, but multiple sub-interfaces. This allows us to use both the static and dynamic network configurations at the same time. Connecting the Accuraspray to your facility’s network is the easiest way to set-up the Accuraspray. An address will be obtained from your DHCP server, and you can connect to the Accuraspray directly (<http://accurag4-12345678>). Change the numbers to match the serial number of your machine. The DHCP IP is displayed in the system tab for reference only. It cannot be changed since it is provided by your DHCP server as mentioned previously. Refer to the document [“Accuraspray 4.0 Network Connections”](#) for in-dept details.

### 3.9.8. Changing the PLC IP

Changing the PLC IP will change the IP of Tecnar’s PLC in the controller’s database. You must also update the IP in the PLC itself, as this only tells the controller which IP to look for when establishing the connection. Make sure that the controller, Tecnar’s PLC, and your own PLC are all on the same network/subnet.

### 3.9.9. Changing the time zone

Change the time zone to match your local settings using the drop-down selector. This UTC/GMT format matches the default time zone used by Windows systems. If you are not sure which one to choose, refer to your local Windows settings or simply google “what’s my time zone”. The picture below is an example using UTC-05. Please note that the NTP server is not enabled on the controller, as it is not connected to the Internet. You may have to adjust the time zone manually to compensate for your local DST settings.

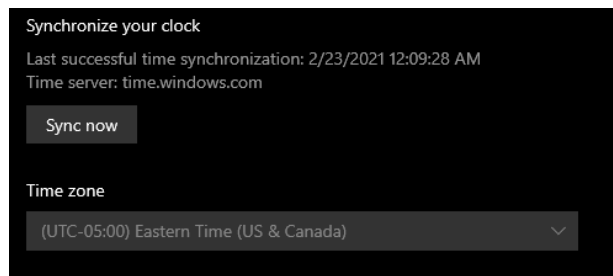

FIGURE 28 - WINDOWS TIME ZONE EXAMPLE

### 3.9.10. Updating your system

Download the latest update archive (.7z) from Tecnar’s website and update your system gracefully with a single click. Upload the archive and click “Start Update”. Simply follow the on-screen instructions. The UI will automatically refresh once the update is finished. If not, refresh the page manually.

## 4. TECHNICAL SPECIFICATIONS

### 4.1. SENSOR HEAD

Parameters	Description
Width	110 mm (4.33 in.)
Height	62 mm (2.44 in.)
Length	790 mm (31.10 in.)
Weight	1.85 kg (4.1 lb.)
Working distance from spray gun axis	200 mm (7.87 in.)
Particle temperature measurement range	1,000°C (1,832 °F) and higher at 3% accuracy
Particle velocity measurement range	5 – 1,200 m/s at 3% accuracy
Plume relative intensity measurement	5% precision
Plume geometry measurement	0.1 mm (0.004 in.) accuracy
Camera field of view	400 mm (15.75 in.)
Particle's measurement volume	3.2 mm x 10 mm x 25 mm (0.13 in. x 0.39 in. x 0.98 in.)

### 4.2. CONTROLLER

Parameters	Description
Width (a)	230 mm (9.06 in.)
Height (b)	100 mm (3.94 in.)
Length (c)	230 mm (9.06 in.)
Weight	4.40 kg (9.7 lb.)
Power requirement	100–240 VAC, 50–60 Hz, 1.5 A, auto-switch

## 5. INSTALLATION

### INSTALLING THE SENSOR HEAD

#### 5.1. UNPACKING THE PARTS

Carefully open the box, remove the content, and set it on a work surface. The box should contain the following items:

1. Sensor head
2. Controller
3. Substrate pyrometer and its support bracket (optional)
4. Air filter and hoses
5. Controller power cable
6. Communication cable between the head and controller

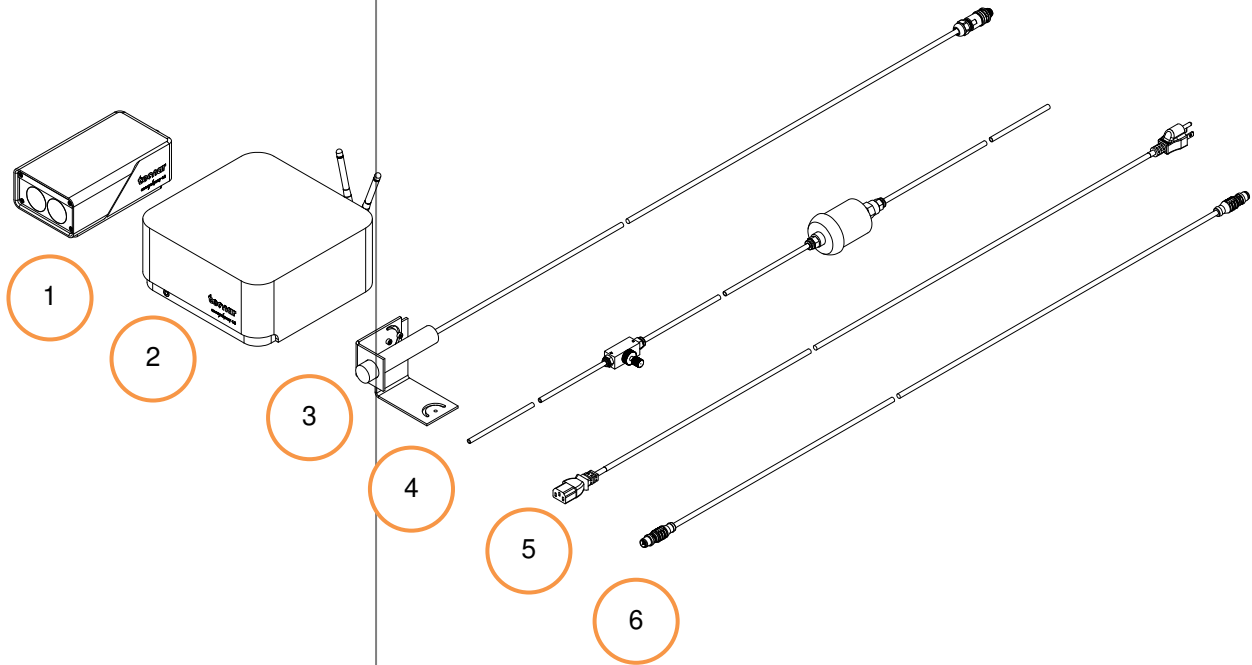

FIGURE 29 - UNPACKING THE PARTS

**5.2. INSTALLING THE SENSOR HEAD**

**5.2.1. Where to install**

Install the sensor head in the spray booth at a location easily reachable by the robot (spray gun). Also, ensure that the sensor head does not interfere with normal spraying operations.

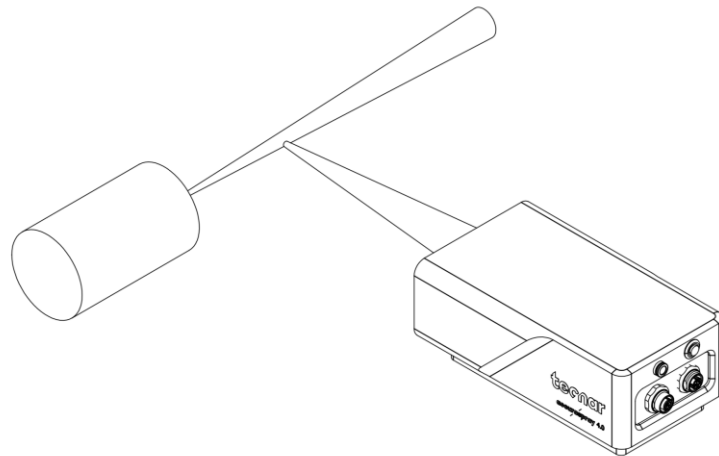

FIGURE 30 - POSITION OF THE SENSOR HEAD

Install the sensor head on a sturdy mounting that does not vibrate or move during spraying. Refer to the following schematic of the Accuraspray mounting plate.

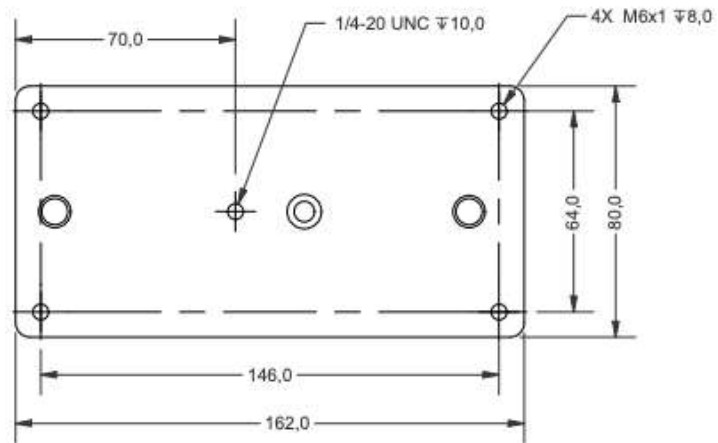

FIGURE 31 - SENSOR HEAD MONTING PLATE DIMENSIONS

**5.2.2. Installation procedure**

Attach the sensor head mounting plate to your support bracket using the 4 mounting holes.

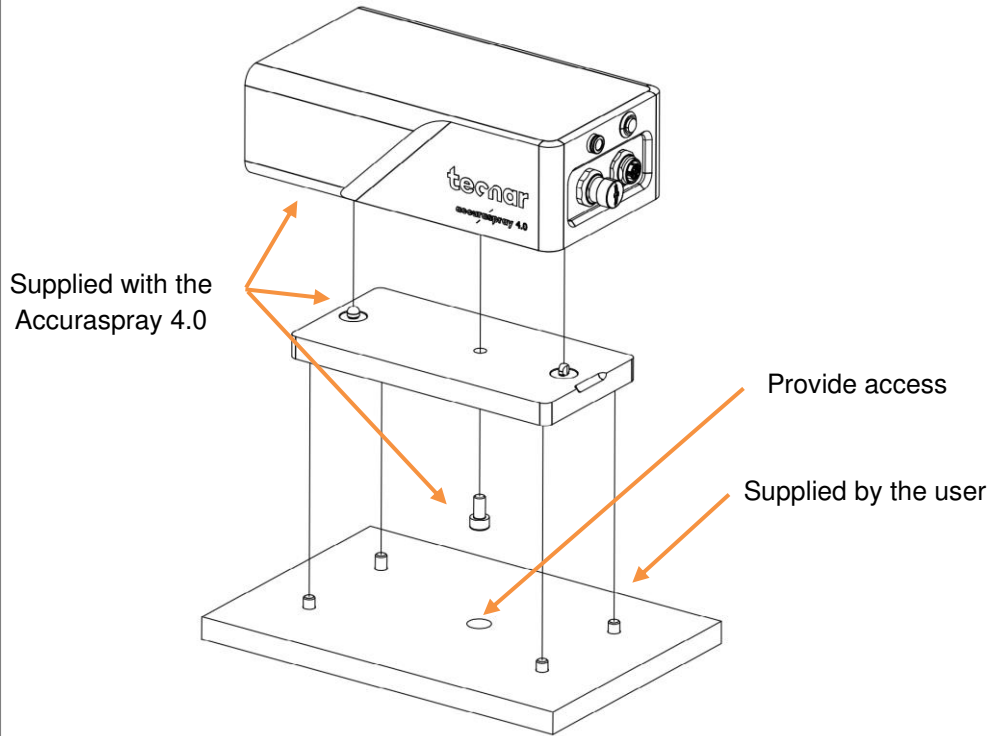

FIGURE 32 - MOUNTING THE SENSOR HEAD

Connect compressed air supply and communication cable to the sensor head. Pull the other end of the communication cable out of the spray booth. Connect the air hoses to the booth air supply.

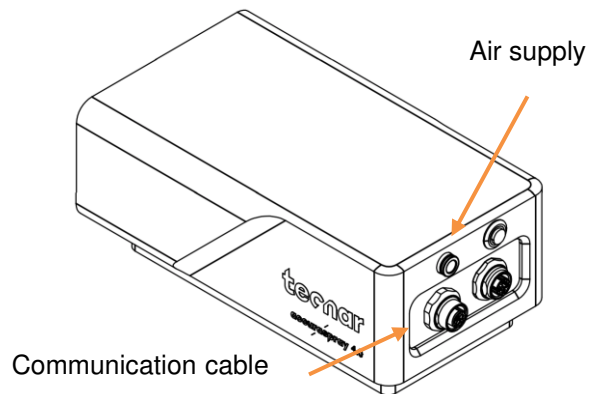

FIGURE 33 - SENSOR HEAD INTERFACE

**5.3. INSTALLING THE CONTROLLER**

**5.3.1. Where to install**

Install the controller outside the spray booth, ideally, close to the booth control equipment.

**5.3.2. Installation procedure**

Connect the sensor head communication cable.

Connect the power cable to the controller and into a power socket.

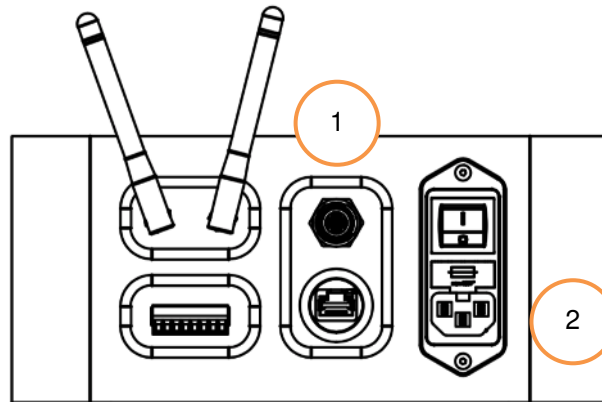

FIGURE 34 - CONTROLLER INTERFACE

Flip the Accuraspray controller power switch to ON. Wait until the LED turns green.

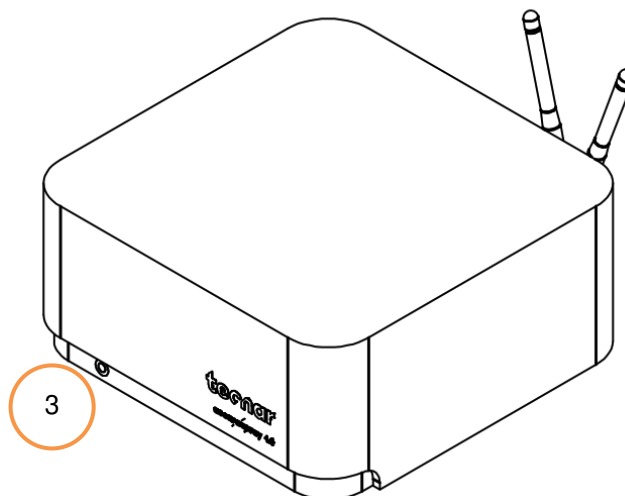

FIGURE 35 - CONTROLLER STATUS LED

**5.4. ADJUSTING THE SPRAY GUN POSITION**

Activate the alignment beam using the push button located at the back of the sensor.

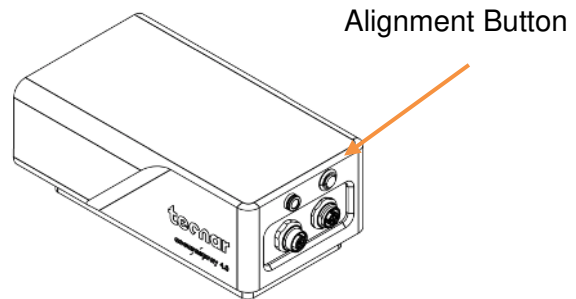

FIGURE 36 - SENSOR HEAD ALIGNEMENT BUTTON

Bring the spray gun near the sensor head as shown on the schematic below. The sensor measurement point is normally set to your standard process spray distance.

The distance between the front of the sensor head and the spray torch axis should be adjusted to 200mm.

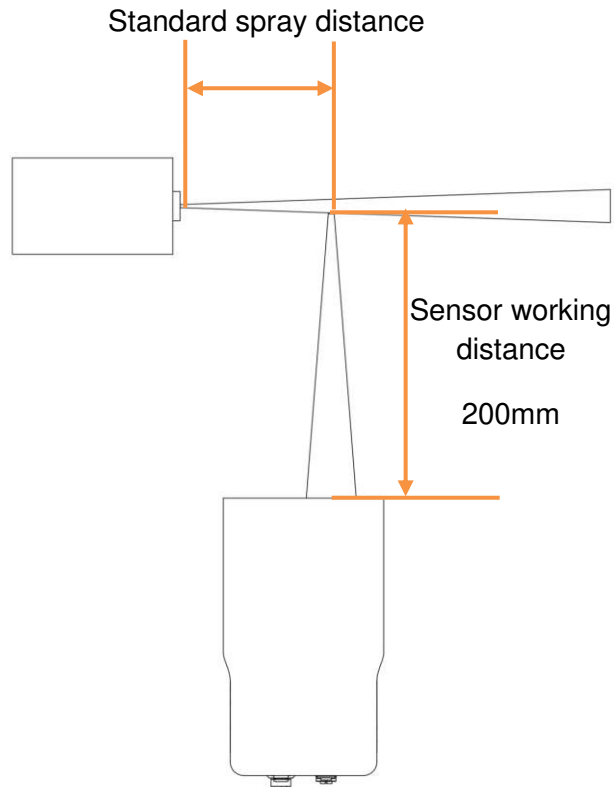
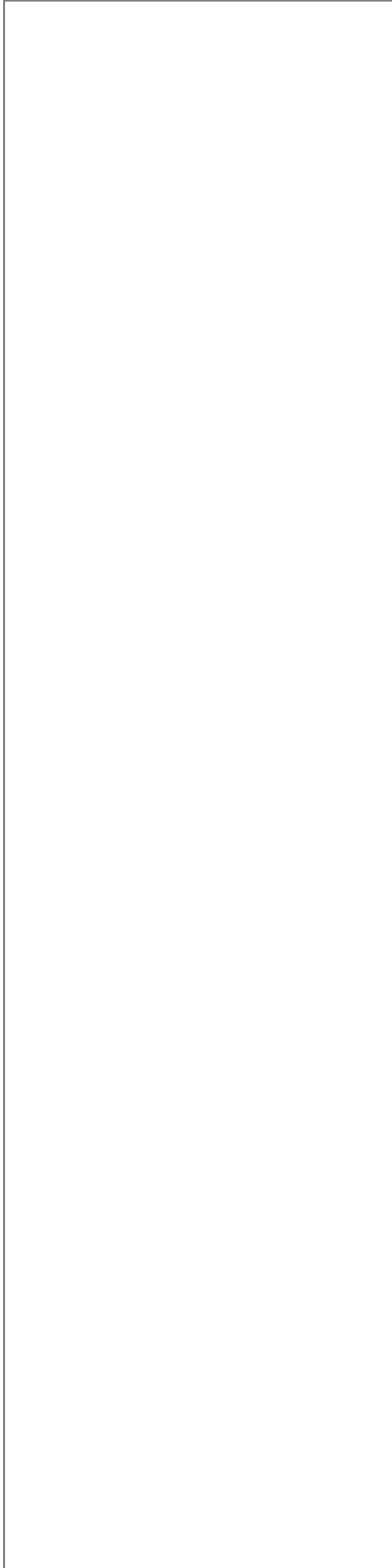

FIGURE 37 - SENSOR HEAD WORKING DISTANCE

Save the new position as Sensor Home on the spray gun.





**5.5. ACCESSING THE USER INTERFACE**

The Accuraspray 4.0 user interface is accessible through a web browser, but it is not actually hosted on the internet. It is streamed from the Accuraspray controller. We recommend using Google Chrome or Microsoft Edge for optimal performance.

Go to the Wi-Fi menu on your computer or tablet and look for “Accura 4.0 – serial number”. The password to access the Wi-Fi is “accura.wifi”.

Open your browser and enter the URL: <http://accurag4-00000000/> to connect to the Accuraspray user interface. Replace the zeros by the serial number of the unit you are trying to reach. The serial number is composed of 8 digits which can be found in the Wi-Fi network name or under the controller. Refer to the document “[Accuraspray 4.0 Network Connections](#)” for in-dept details.

**5.6. SETTING UP THE ACCURASPRAY ON A NETWORK (OPTIONAL)**

To connect the Accuraspray to your local network you must connect the controller to the network with an Ethernet cable. Refer to the document [“Accuraspray 4.0 Network Connections”](#) for in-dept details.

**5.7. CONNECTING THE I/Os (OPTIONAL)**

You may remotely control the Accuraspray using the I/O connections.

To use the I/O connections, please refer to the following schematic and descriptions.

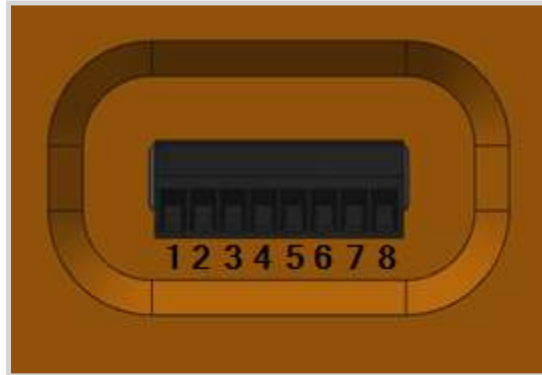

FIGURE 38 - I/O PORTS

**5.8. USING THE INPUT TO GENERATE REPORTS**

The Input can be used to automatically generate reports and .csv files. It must be held ‘high’ for at least 1 second to be detected by the controller. The input status is fetched every 500ms. If you set the input ‘high’ for more than 1 second but less than the reaction time, the auto-generated report length will be set to 1 second. Therefore, the system will record 1 second of data after the reaction time. This is a safety measure, not a feature. The csv will most likely contain a single line, and the graphs cannot be plotted.

The typical usage is to set the input “high” for more than the reaction time. The auto-generated report length will be set to (“input high time” – “reaction time”). For example, if you set the reaction time to 5 seconds and leave the input “high” for 10 seconds, the auto-generated report will contain 5 seconds of data, starting after the 5 seconds reaction time. While recording using the input, you cannot save reports or videos through the User Interface, and vice-versa.

Pin	Name	Description	Logic
1	IN 24 VDC	Input/Output reference Voltage + Supplied by user	
2	IN 0 VDC	Input/Output reference Voltage – Supplied by user	
3	IN 1	Start measurement sequence (the data acquired by the Accuraspray will be saved) when logic is 1 and stop when logic is 0	Logic <u>1</u> : 11-24V above 0VDC IN Logic <u>0</u> : 0-5V above 0VDC IN
4	OUT 1	Wait for data acquisition. This output indicates that the sensor is acquiring its initial data buffer. Once the buffer is filled, this output will fall.	Logic rising edge: Acquiring initial buffer Logic falling edge: Initial buffer acquired
5	OUT 2	Measurement valid. Following the acquisition of the first buffer this output 1 will be raised when measurements are valid.  If the measurements are invalid, <a href="#">error messages</a> will be displayed in the user interface and measurements results should be ignored.	Logic <u>1</u> : 24 VDC IN Logic <u>0</u> : 0 VDC IN
6	OUT 3	All measurements are within the <a href="#">green zone</a> .	Logic <u>1</u> : 24 VDC IN Logic <u>0</u> : 0 VDC IN
7	OUT 4	At least one measurement is within the <a href="#">yellow zone</a> .	Logic <u>1</u> : 24 VDC IN Logic <u>0</u> : 0 VDC IN
8	OUT 5	At least one measurement is within the <a href="#">red zone</a> .	Logic <u>1</u> : 24 VDC IN Logic <u>0</u> : 0 VDC IN

## 6. MAINTENANCE

### 6.1. MAINTENANCE SCHEDULE

Components	Actions	Frequency
Sensor head	<a href="#">Cleaning the sensor head windows</a>	Daily
	<a href="#">Replacing the sensor head windows assembly</a>	When damaged
	<a href="#">Sensor head calibration</a>	Annually
Compressed air filter cartridge	Replacing the filter cartridge	Periodically (see visual indicator on the cartridge assembly)

**6.2. MAINTENANCE PROCEDURES**

**6.2.1. CLEANING THE SENSOR HEAD WINDOWS**

To ensure accurate measurements, the sensor head windows must be free of dust, oil, and scratches. The sensor head windows must be cleaned after each measurement procedure.

Tools and materials required:

- Compressed air
- Lens optical cloth
- Isopropanol (rubbing alcohol)

Instructions

- Blow clean & dry compressed air on the windows.
- If any marks remain, clean the windows with an optical cloth. Wipe the paper across the window in a single motion instead of rubbing back and forth.
- If any marks remain, clean the windows with lens paper and a small amount of isopropanol. Wipe the paper across the window in a single motion instead of rubbing back and forth.
- If any marks remain, replace the sensor head window assembly (see next section).

**6.2.2. REPLACING THE SENSOR HEAD WINDOW ASSEMBLY**

We recommend using latex or nitrile gloves when replacing the sensor head window plate. To avoid damaging the lens, do not use your fingers or sharp objects.

Tools and materials required:

- Latex or nitrile gloves
- 2.5 mm Allen key
- Sensor head window plate (20303-00930-00)

Instructions

- Remove the four M3 screws and carefully remove the window assembly.
- Put the new assembly on the sensor with the air knife at the top (facing downward). Insert the four M3 screws to secure the plate.

**6.2.3. CALIBRATING THE SENSOR HEAD**

All sensor heads are calibrated at Tecnar before being shipped to the end-users. To ensure accurate measurements, sensor calibration should be verified every year so that their calibration is NIST-traceable.

You must send the sensor heads to Tecnar Automation Ltd every year for calibration, contact [service@tecnar.com](mailto:service@tecnar.com). There is no need to send the cables and controller.

**RECOMMENDED SPARE PARTS**

Components	Part number
Compressed air filter cartridge	10201-00599-00
Sensor head windows assembly	20303-00930-00

## 7. TROUBLESHOOTING

On power-up of the controller, once the sensor is initialized properly, the head’s back-plate LED will start blinking quickly (3 quick blinks every 5 seconds). This initial blinking indicates that the electronics components inside the sensor are up and running, and that the sensor is waiting for the software to connect. Note that the back-plate LED button is not available during this initialization sequence. Once the software is connected to the sensor, the LED will stop blinking immediately, and the back-plate button becomes available. Thus, it can now be used for alignment purposes. The start-up time of the controller is usually as fast as the initialization of the sensor head. Depending on the start-up time duration, the blinking might be hard to notice if the controller connects to the sensor as soon as it is initialized. This process usually takes less than 30 seconds.

In the event that the initialization sequence is not successful, the LED will not stop blinking. Instead, it will start blinking more slowly, indicating that the sensor is now in error state (the LED will be held ON for approximately 1.5 seconds instead of 166 milliseconds, maintaining a 5 second interval in between the blinks). The back-plate button will remain disabled. Refer to the troubleshooting section for more information on the LED error codes.

### 7.1. LED ERROR CODES

As mentioned previously, in the case of hardware failure, the back-plate LED is used as a troubleshooting tool to provide more information on the system error state. Here is a list of all the possible codes, descriptions, and troubleshooting actions to be taken.

Error code	Description	Actions
2 blinks	The controller did not connect to the sensor within 2 minutes after the initialization	Reboot the controller
3 blinks	Internal micro-switch error	Contact Tecnar service team
4 blinks	Microcontroller error	Contact Tecnar service team

7.2. ERROR REPORTING IN THE USER INTERFACE

Error code	Corrective measures
Invalid velocity measurement (Low correlation)	<ul style="list-style-type: none"> <li>The sensor head is aimed perpendicular to the spray plume and is 200mm.</li> <li>The sensor head is 200mm away from the center of the spray plume.</li> <li>The SPRAY DIRECTION is set correctly.</li> <li>The spray plume angle is no more than <math>\pm 15^\circ</math>.</li> </ul>
Invalid velocity & temperature measurements (Signal level too low)	<ul style="list-style-type: none"> <li>The sensor head is aimed at the spray plume.</li> <li>The proper setup has been selected.</li> <li>Powder is injected into the spray plume.</li> <li>The sensor head windows are clean.</li> <li>The SIGNAL AMPLIFICATION is set adequately for your process.</li> </ul>
Invalid velocity & temperature measurements (Saturated signal)	<ul style="list-style-type: none"> <li>The proper setup has been selected.</li> <li>The SIGNAL AMPLIFICATION is set adequately for your process.</li> </ul>
Invalid plume width, plume deviation, plume intensity & density measurements (Signal level too low)	<ul style="list-style-type: none"> <li>The proper setup has been selected.</li> <li>The sensor head windows are clean.</li> <li>EXPOSURE TIME is set adequately for your process.</li> </ul>
Invalid measurements (Saturated signal)	<ul style="list-style-type: none"> <li>The proper setup has been selected.</li> <li>EXPOSURE TIME is set adequately for your process.</li> </ul>



### 7.3. SERVICE & SUPPORT

Should you have any questions concerning our equipment, please contact us at:

TECNAR Automation

1021, Marie-Victorin Street,

St-Bruno, Qc, Canada, J3V 0M7

Phone: 450-461-1221 ext. 232

Fax: 450-461-0808

Email: [service@spraysensors.tecnar.com](mailto:service@spraysensors.tecnar.com)

## 8. RELATED DOCUMENTS

### 40107-00046: “Accuraspray 4.0 Profinet PLC Configuration”

This document provides additional information on the PLC Profinet interface, integration, and database structure.

### 40107-00047: “Accuraspray 4.0 Network Connections”

This document explains every possible connection method that can be used to connect one or multiple Accuraspray Controller to your network.

### 40107-00048: “Accuraspray 4.0 Http Communication”

The following document describes the communication protocol used by the Accuraspray 4.0 to stream measurement data and load setups (system configurations) remotely.

## APPENDIX A PLUME ANGLE MEASUREMENT

### A.1. PHILOSOPHY AND MEASUREMENT PRINCIPLE

The plume angle has been added in software version 1.5.0. This is a new gauge that measures the real angle of the plume at the standoff distance, not to be confused with the previous “Plume Angle” parameter in the setup. The “Plume Angle” parameter has been renamed to “Sampling Angle” to better reflect its functionality. However, this gauge has been added to monitor the plume angle over time, to evidently detect changes in the spray plume.

Generally, the plume angle is more relevant for Plasma and Wire Arc spray processes, but it can also be used for any type of process. The calculation method makes it very versatile, independent of the process.

### A.2. HOW THE PLUME ANGLE IS CALCULATED

The software draws 3 vertical lines across the full height of the screen, near the bull’s eye horizontal position. One of the three lines is exactly at the horizontal midpoint. The lines are concentrated in the middle of the screen, but the spacing is wide enough so that we get an accurate measurement from frame to frame. The 2 additional lines are located 50 pixels apart from the center line (at the horizontal midpoint).

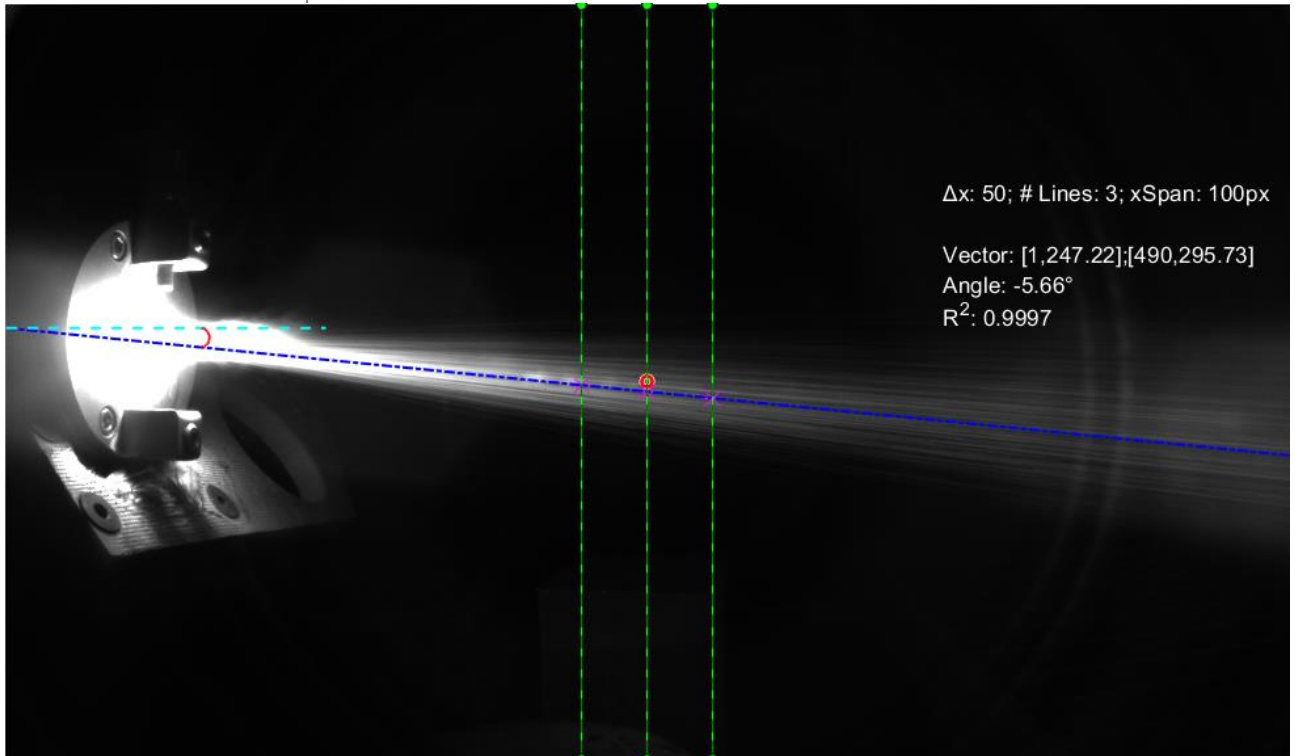
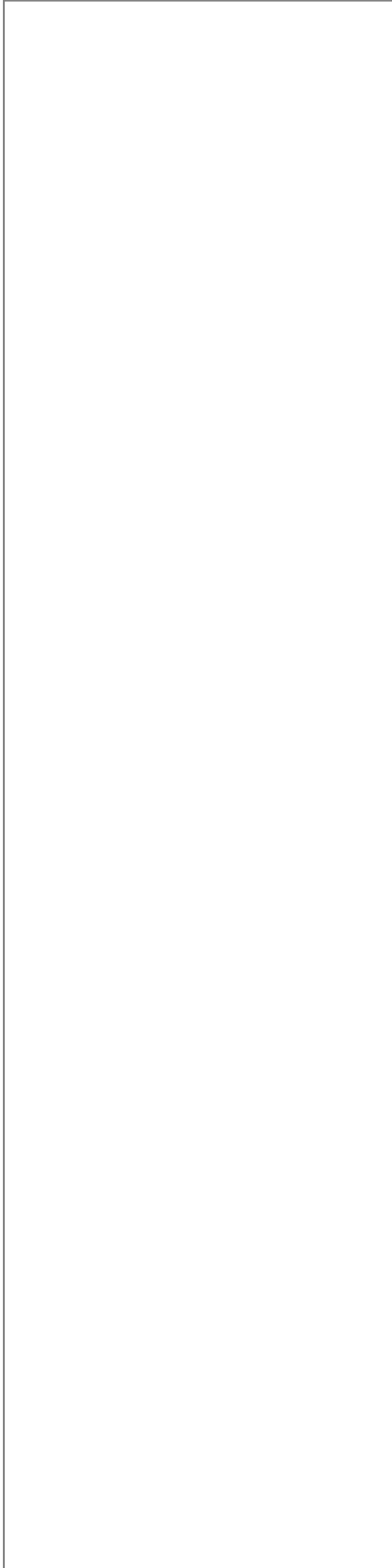

FIGURE 39 - POSITION OF THE 3 LINES USED FOR THE PLUME ANGLE CALCULATION



As mentioned previously, the total number of lines used to calculate the plume angle is 3. Here is a picture showing the positions of the lines:

The plume angle is always relative to the horizontal plane. In this case, the angle is  $-5.66^\circ$ . Note that the plume angle does not use the data from sampling angle. This algorithm uses all the pixels across these 3 lines to determine the plume angle. Consequently, it is able to determine the angle even in extremely harsh conditions, where the angle is absurdly high (in absolute value).

The algorithm stores the intensity across the 3 lines in separate buffers. For each line, it will then try to find the “center of mass” of that line. At last, using these 3 centers, we simply fit a straight line across (represented by the blue line in figure 29). The resulting linear equation can then be used directly to find the plume angle.

Using the linear equation from the fit:

$$y = b_1 * x + b_0$$

Calculate the angle directly from the slope  $b_1$ :

$$plume\ angle = \tan^{-1} \left[ \frac{1}{b_1} \right] * \frac{180}{\pi}$$

This process is performed 20 times per second (once per frame). The “instantaneous” measurement of the plume angle is stored in a “first in first out” (FIFO) buffer, just like all the other measurements. The reaction time of this FIFO is governed by the global reaction time, which is determined by your process response time. Whenever the measurement is updated, whether it’s in the UI or in the csv, it will always reflect the average of the FIFO buffer at that given time. All other measurements also behave this way.

The plume angle gauge is located next to the plume deviation at the bottom right of the screen. The image below reveals the difference between the plume angle (in yellow) and the sampling angle (in red):

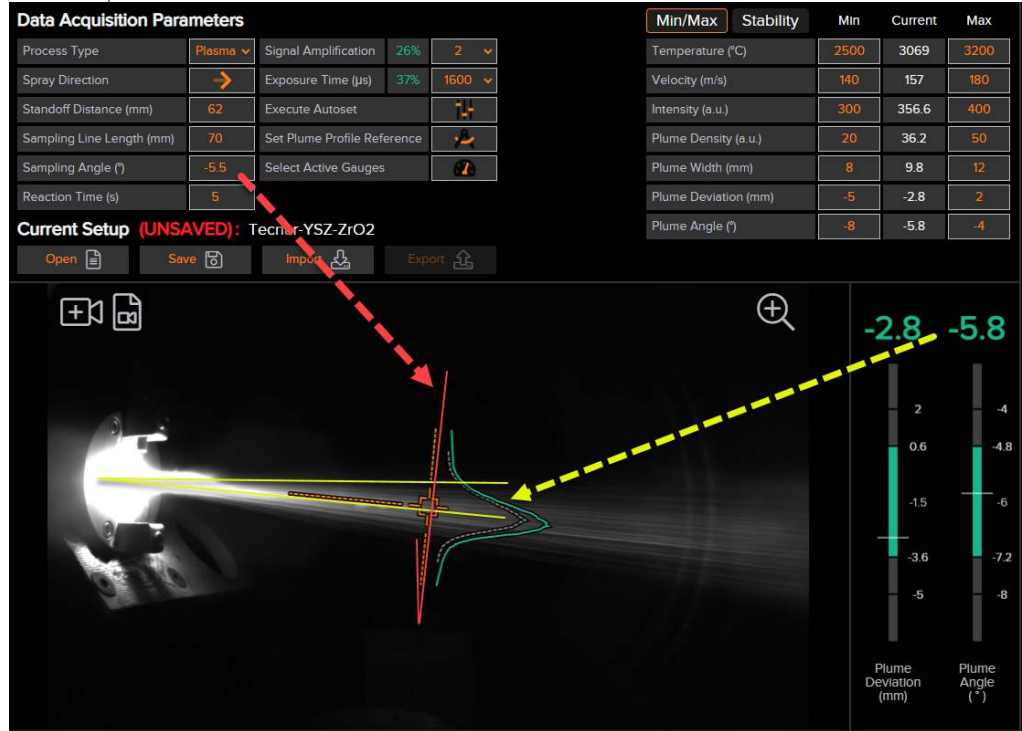

FIGURE 40 - PLUME ANGLE AND SAMPLING ANGLE COMPARISON

## APPENDIX B PROCESS STABILITY

### B.1. PHILOSOPHY AND MEASUREMENT PRINCIPLE

The stability features have been introduced in software version 1.7.0. Imagine a process that fluctuates within a short time frame. Depending on your min/max settings and the duration of this instability, the average measurement may still fall within the green zone however the standard deviation for this measurement may be outside the green zone producing a sub-optimal coating. To have better control on the stability of the process, the stability gauge comes into play. Though this concept is statistics based however, this tool is extremely flexible, and you may choose your own thresholds experimentally that do not necessarily follow statistical principles.

The base metric for the stability measurements in the Standard Deviation (SD) of the population contained in the FIFO buffers at any given time. Each measurement has its own timed queue. These buffers are simply moving averages based on the reaction time of the current setup. The acquisition rates of the scope and the camera are set to 25 Hz and 20 Hz respectively. Hence, using a 5 second moving average, we would have a total of 125 entries for scope measurements (temperature, velocity), and 100 entries for camera measurements (all the other measurements) at any given time. Every time a new value is inserted, the software computes the new average and the new standard deviation of that population.

Each gauge has its own stability measurement. However, the software only uses one “global” stability indicator, called the “Process Stability”. How the process stability is calculated depends on the calculation method. There are two calculation methods: strict and average. More details regarding these methods will follow.

For the time being, let’s focus on a single stability indicator. A total of 3 thresholds are required to set the proper limits for the stability gauge.

- The standard deviation reference
- The standard deviation yellow threshold
- The standard deviation red threshold

The reference is the “typical” deviation for that kind of process under normal conditions. Therefore, when set properly, the probability of being stable is 100% for values below this threshold. As the SD increases, the probability of being stable will start to decrease, and eventually reach the yellow threshold. For all values BELOW the yellow threshold, OUT3 will be set high (green signal). If the standard deviation is HIGHER than the yellow threshold, OUT4 will be set high (yellow signal). If it keeps decreasing, it will eventually reach the red threshold, and OUT5 will be set high instead (red signal). Remember that these 3 output states are mutually exclusive, red being the highest priority. Additional details about the thresholds and how to set them properly are provided in the following sections.

**OVERVIEW OF THE STABILITY PANEL**

The top half of the screen lets you adjust the parameters related to the stability. On the right side, like the min max settings, you will find the different thresholds for each measurement. In addition, the current standard deviation value is displayed in a separate box. Next to the “SD Red Threshold”, a checkbox lets you activate or deactivate individual measurements. In other words, you have the freedom to select the stability gauges that are relevant to you. Finally, at the right edge of the screen, a status circle displays the current stability status for that measurement.



FIGURE 41 - STABILITY TOP PANEL

The bottom half of the screen lets you review the data for the current run or a previous run. When running a stability analysis, the controller generates a regular production file. Then, it reads the content of the csv file to generate the distribution charts and calculate the thresholds. You can also load any csv file generated by the Accuraspray to review and use the data from previous runs. Here is an overview of the bottom panel:

As we can tell from the figure, there are two chart types: distribution and time. The current graph is the distribution (the current selection is highlighted with a white border). In this pane, you can select the chart that you wish to review, update its threshold, update the thresholds for all measurements, or load a csv file. Additionally, when the distribution mode is selected, you can adjust the number of bins.

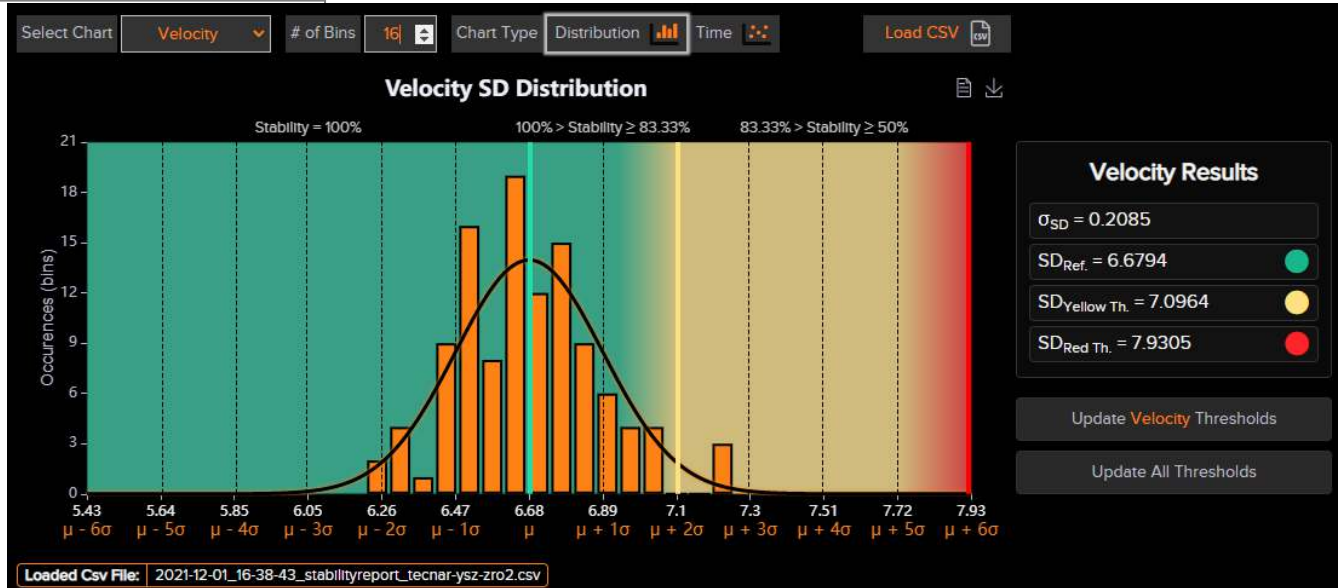

FIGURE 42 - STABILITY BOTTOM PANEL

### THE DISTRIBUTION CHART

#### INTRODUCTION TO NORMAL DISTRIBUTION

In probability theory, the probability density function (PDF) represents a likelihood to fall within a certain range, and it is generally represented by the Gaussian equation:

$$f(x) = \frac{1}{\sigma * \sqrt{2 * \pi}} * e^{-\frac{1}{2} * \left(\frac{x-\mu}{\sigma}\right)^2}$$

In the current context, the parameter  $\mu$  represents the SD (standard deviation) of the timed queue population. To clarify, the base metric being the standard deviation, the distribution generated is the distribution of the standard deviation. Since the rejections criteria are applied on the SD, the distribution is based on the SD as well. Consequently, the  $\sigma$  in the equation above represents the “standard deviation of the standard deviation” in our current context. When the data is normally distributed, the probability density function is a bell-shaped curve, as show in the picture below:



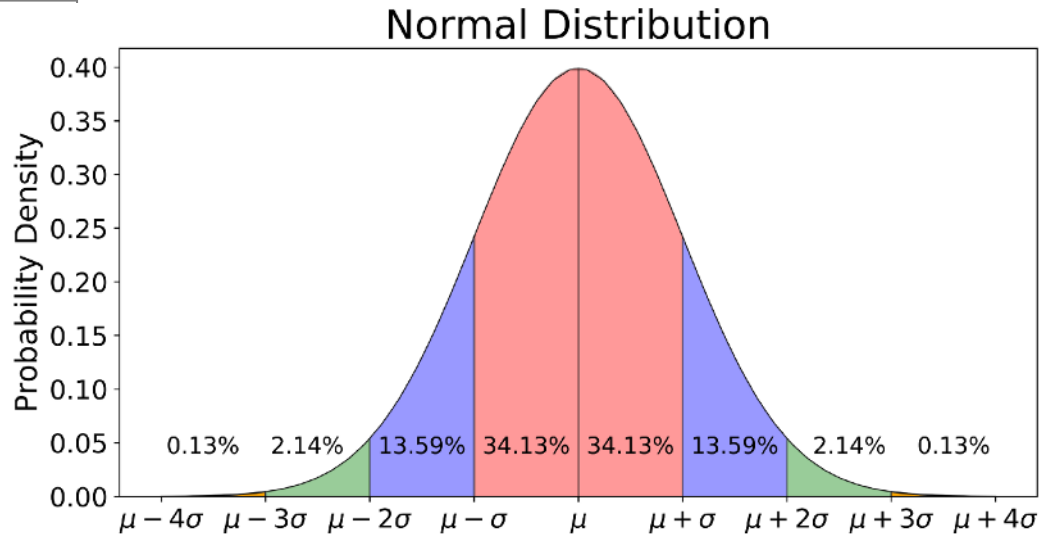

FIGURE 43 - NORMAL DISTRIBUTION

From "Explaining the 68-95-99.7 rule for a Normal Distribution, by Michael Galarnyk, 2018.  
<https://towardsdatascience.com/understanding-the-68-95-99-7-rule-for-a-normal-distribution-b7b7cbf760c2>

As shown in the figure, there is a 50% chance for the value to be below the average ( $\mu$ ) of the distribution. Furthermore, the chance to fall below  $\mu + 2\sigma$  is:

$$50\% + 34.13\% + 13.59\% \cong 97.72\%$$

Tecnar has chosen to use  $2\sigma$  as the threshold starting point for the yellow thresholds, if you decide to generate the thresholds automatically in the UI. You can always update the thresholds manually if you wish to use a different approach. The red threshold is set at a level where manual intervention is required to adjust or stop production to avoid bad coatings. The automatically generated value is  $\mu + 6\sigma$ . Once again, for a normally distributed dataset, we can declare that any value beyond that threshold is more than 99.99% likely to NOT be stable.

**B.2. EXAMPLE USING REAL DATA**

In the example below, we are focusing on the velocity measurement to understand how the thresholds are calculated and applied. You will also notice that the only “active” stability measurement is the velocity.



FIGURE 44 - EXAMPLE USING THE VELOCITY STANDARD DEVIATION

Here are the results:

- The velocity SD average is 6.6794 m/s ( $\mu_{SD}$ ).
- The standard deviation of the standard deviation ( $\sigma_{SD}$ ) is 0.2085 m/s.
- The yellow threshold is set to  $\mu_{SD} + 2 * \sigma_{SD} = 7.0964$  m/s.
- The red threshold is set to  $\mu_{SD} + 6 * \sigma_{SD} = 7.9305$  m/s.

We can easily tell from the graph that most of the data falls within the green zone. Only one bin is in the yellow zone. That bin represents 2.68% of the total area of the bins. As we have seen in the previous section, the theoretical value for combination of the yellow and the red zone should be around 2.28%. That tells us that this dataset follows a normal distribution. In this case, setting the yellow limit to 7.0964 m/s would mean that 97.32% of the time, we'd fall within the green zone (100% - 2.68%). Using this we can say that the stability reading is unusually high, and it's drifting towards instability.

Additionally, the chart embeds a lot of information in the tooltips. Scroll over the different thresholds, bins, or areas to view the tooltips. Here is an example when hovering over the area in-between the green and the yellow thresholds:

As illustrated, the coverage of the area in-between  $\mu$  and  $\mu + 2\sigma$  is 44.64%, which is close to the theoretical target of 47.72%. For SD values within this range, we expect a process stability between 100% and 83.33%.

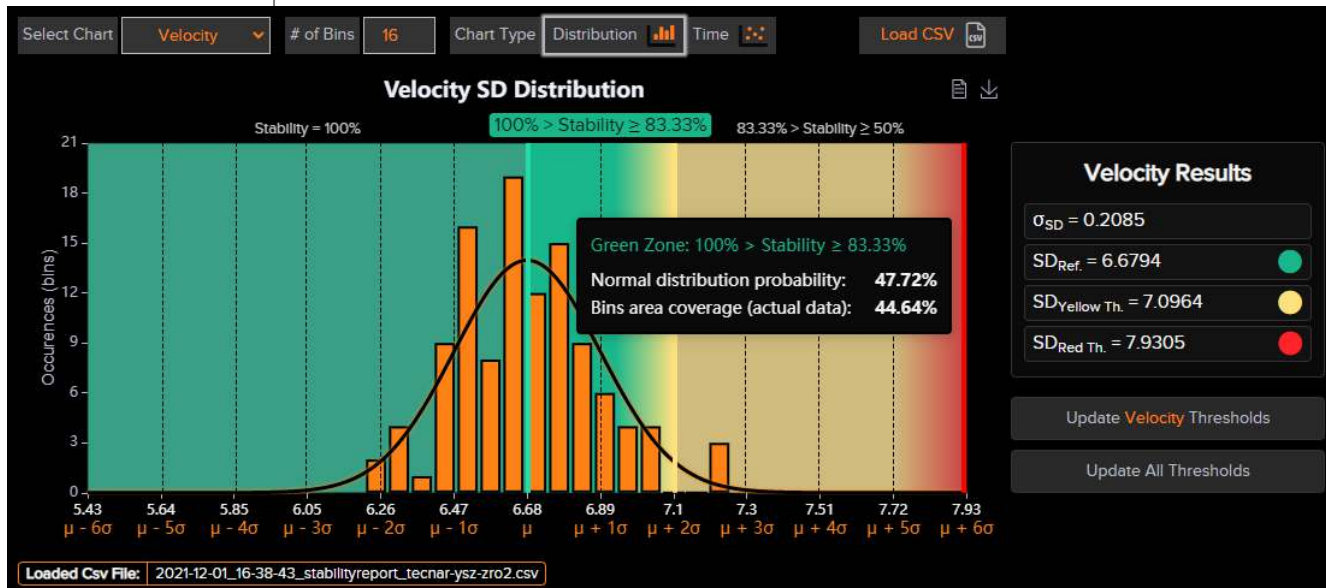

FIGURE 45 - VELOCITY STABILITY GREEN ZONE AREA COVERAGE

### FROM THE DISTRIBUTION CHART TO THE STABILITY GAUGE

The “Process Stability” value can be anything between 0 and 100%. To establish the relationship between the distribution chart and the stability gauge, the SD value must be normalized based on the position of the thresholds. The green threshold always represents 100% stability. As for the red threshold, it represents 50%. This cannot be changed. However, the yellow threshold is dynamic. It can be interpreted as a percentage of the red threshold, relative to the green threshold. Thus, using the default thresholds, the yellow threshold is one third of the red limit. Because the span between the green and the red threshold is 50%, this is equivalent to 16.66%. In addition, because the green threshold is set to 100% stability, the yellow threshold becomes  $100\% - 16.66\% = 83.33\%$ . Consequently, if you chose to set your yellow thresholds manually, the stability percentage that it represents may not always be 83.33%.

Hence, assuming the default thresholds, the ranges will be set as follows:

- For all SD values below the “Standard Deviation Reference” ( $\mu_{SD}$ ), the process stability will be set to 100%.
- For all SD values in-between the “Standard Deviation Reference” and the “Standard Deviation Yellow Threshold”, the process stability will range from 100% to 83.33%.
- For all SD values in-between the “Standard Deviation Yellow Threshold” and the “Standard Deviation Red Threshold”, the process stability will range from 83.33% to 50%.
- For all SD values above the “Standard Deviation Red Threshold” ( $\mu_{SD} + 6 * \sigma_{SD}$ ), the process stability will range from 50% to 0%.

**PERFORMING A STABILITY ANALYSIS IN REAL-TIME**

The usefulness of this tool is to allow users to perform stability analysis in real-time instead of processing the data externally in Excel. To do so, simply click on the “Start Stability Analysis Button” at the top left. You may want to adjust the “Analysis Duration” before doing so. The analysis duration should be set to a value large enough that it covers the “response time” of the system. In most cases, 1 or 2 minutes should be plenty to cover the engulf the pulsation of the process (cycle time).

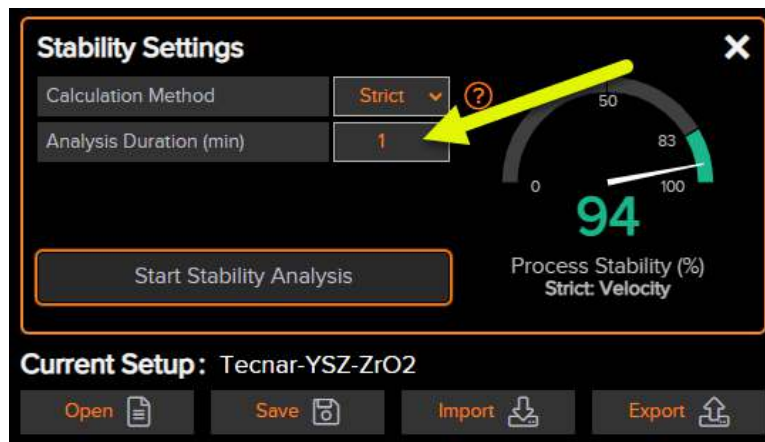

FIGURE 46 - ADJUSTING THE STABILITY ANALYSIS DURATION

Once the process is finished, this menu will appear:

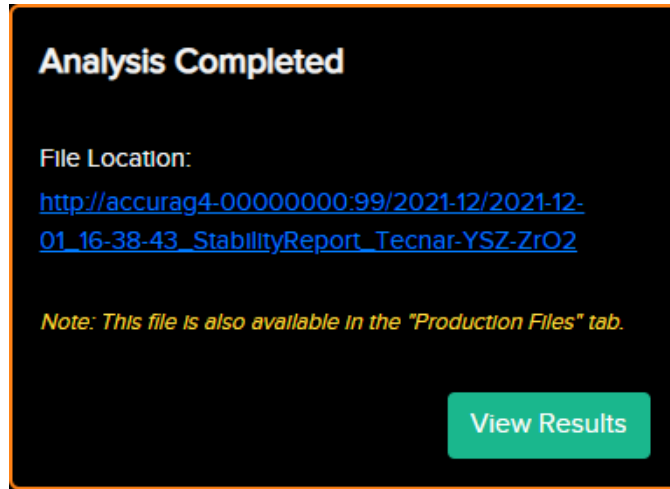

FIGURE 47 - STABILITY ANALYSIS COMPLETION

You can either click on the link to download the file or view the results directly. Clicking on the link will open a separate tab where you can download both the csv and the pdf files. These files are stored in the controller, so you can download them anytime by opening the “production reports” tab.

**THE CALCULATION METHODS**

As mentioned previously, there are 2 calculations methods: “strict” and “average”.

- Strict (recommended): The “Process Stability” will display the parameter with the lowest stability among those that are active. The other parameters with a higher stability will be ignored. Since the yellow threshold is dynamic, the lowest stability (%) of the worst color will be selected. Based on your yellow limits, this might not always be the lowest percentage.
- In average mode: All active stability measurements will have an equal weight to calculate the global “Process Stability”. In this mode, the yellow thresholds are ignored and forced to 50% of the red limit (relative to the green limit). This is equivalent to a process stability of 75%. This method is a good starting point until you fully qualify the process.

**ADJUSTING THRESHOLDS BASED ON PREVIOUS RUNS**

The stability analysis can also be performed on any csv file previously generated by the Accuraspray. Simply click the “Load CSV” button and the statistics will be automatically generated. You can also load runs from different controllers if necessary. Therefore, you can use the results to update the thresholds for the currently loaded setup.

**ADJUSTING THRESHOLDS MANUALLY BASED ON MULTIPLE RUNS**

The stability analysis is limited to one csv file, meaning that you cannot “aggregate” files from different runs, booths, guns, etc. Depending on your use case and the level of integration, you may want to build the reference setup based on runs executed in different booths, using different torches, etc. This is a valid approach. However, you will have to process the data externally using Excel, MATLAB, or other external tools to find the proper limits for the aggregated runs.

You could also bypass this limitation by “aggregating” the content of the different csv files into a single file. The Accuraspray will then process the results as if it was one set of data. This will have the same effect as processing the files externally to find your limits. The only thing to keep in mind is that the time domain chart will appear as one cluster of data, and you won’t be able to differentiate the runs by doing so. However, the calculated thresholds will be the same.

