

SHOTMETER-G3

Product Manual, Edition 1

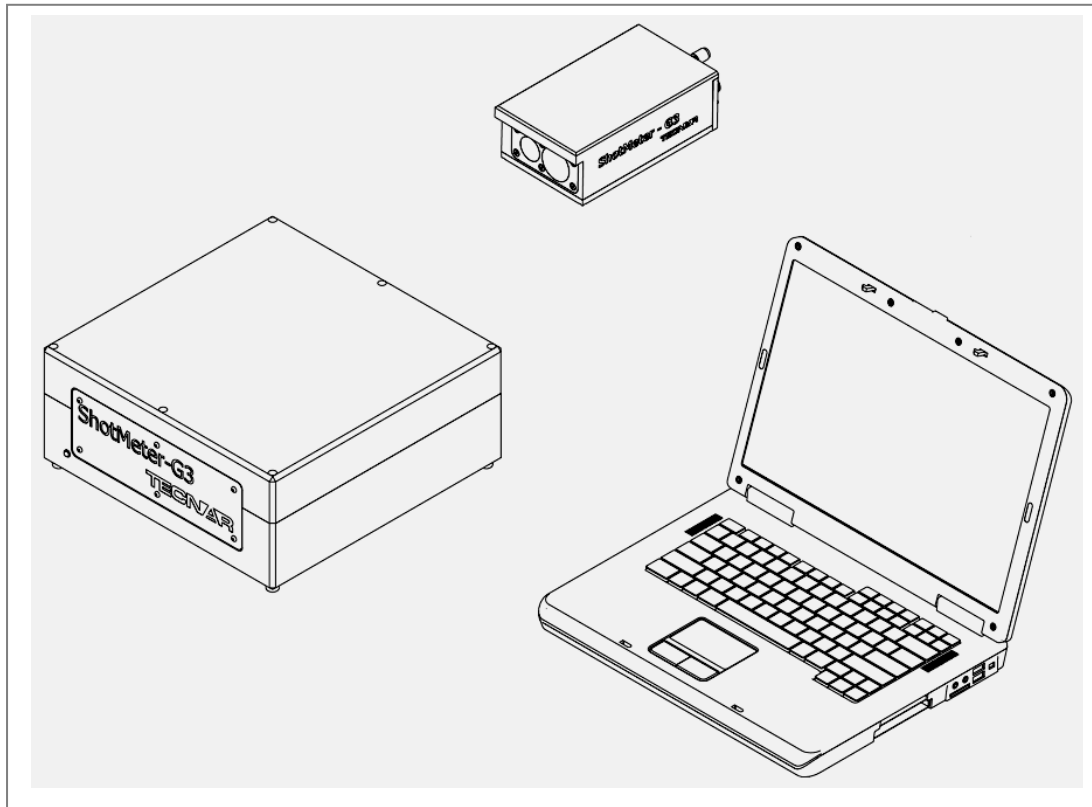

Tecnar Automation Ltd.

1321, Hocquart Street,
St-Bruno, Qc, Canada
J3V 6B5

Phone: 450-461-1221

Fax: 450-461-0808

www.tecnar.com

NOTICES

© 2008 Tecnar Automation Ltd.

No part of this manual may be reproduced in any form or by any means (including electronic storage and retrieval or translation into a foreign language) without prior agreement and written consent from Tecnar Automation Ltd.

MANUAL PART

Shotmeter-G3

EDITION

- Edition 1, March 2012

The material contained in this document is provided “as is” and is subject to change without notice in future editions.

OVERVIEW

Orientation:

- Table of contents at the front of the manual

This manual contains the following sections:

- “Safety”
- “Product description”
- “Installation and commissioning”
- “Maintenance”
- “Operation”
- “APPENDIX”

TABLE OF CONTENTS

SHOTMETER-G3	1
NOTICES.....	2
MANUAL PART	2
EDITION	2
OVERVIEW.....	2
TABLE OF CONTENTS.....	3
1 SAFETY SUMMARY.....	4
1.1 GENERAL PRECAUTIONS.....	4
1.2 AUTHORIZED USE	4
1.3 SAFETY SIGNS	4
2 PRODUCT DESCRIPTION	5
2.1 SHOTMETER-G3 PRODUCT STRUCTURE.....	6
2.2 CONTROLLER CONNECTIONS	8
2.3 SENSOR HEAD CONNECTIONS	9
2.4 SENSOR HEAD WINDOW	9
2.5 CONTROLLER FUNCTION	9
2.6 SENSOR HEAD FUNCTION	10
2.7 DATA FLOW WITHIN CONTROL ARCHITECTURE	11
2.8 TECHNICAL DATA.....	13
3 INSTALLATION AND COMMISSIONING	14
4 MAINTENANCE.....	17
4.1 REPLACEMENT OF SENSOR HEAD WINDOW	17
5 OPERATION	18
5.1 MAIN SCREEN	18
5.2 MENUS.....	22
5.3 SETTINGS.....	24
APPENDIX	34
MAIN POPUP WINDOWS.....	34
FOLDER CONFIGURATION	36
SPARE PART	37
TCP/IP PROTOCOL DETAIL.....	38
GLOSSARY / ACRONYMS.....	41
DESCRIPTION OF FIGURES	42
QUICK TROUBLE-SHOOTING	44
SERVICE & SUPPORT.....	45

1 SAFETY SUMMARY

The following safety precautions should be observed during all phases of operation of the Shotmeter-G3.

Tecnar Automation Ltd. assumes no liability for user's failure to comply with these precautions or with specific warnings elsewhere in this manual.

1.1 GENERAL PRECAUTIONS

- Make sure to use an unloaded, properly grounded power line.
- Supply clean & dry cooling air at 1.7–2.7 bar (25–40psi) to sensor head.
- Use only original spare parts.

1.2 AUTHORIZED USE

Shotmeter-G3 is intended solely for shotpening and gridblasting process monitoring and control use. Any other use is considered as unauthorized.

This manual should be read before the use of the system is authorized and a copy of it should be kept near the equipment.

Shotmeter-G3 has been designed and manufactured according to state of the art technology and world standard safety regulations. However, unauthorized use can result in danger to the operator or third parties' body or even life and/or in damage to the product itself or other machinery.

1.3 SAFETY SIGNS

Signs such as the ones shown in the two examples below indicate particular hazards or risks to consider when operating the Shotmeter-G3:

WARNING

The warning sign denotes a hazard. It warns about dangers which could result in either serious damages to the system or in serious personal injury or even death.

CAUTION

The caution sign denotes a hazard. It warns about dangers which could result in minor personal injury or equipment damage.

2 PRODUCT DESCRIPTION

Shotmeter-G3 was designed to continuously record, display, and compare the following peening/blasting plume parameter against adjustable acceptance parameter ranges:

- Average particle velocity

Note that Shotmeter-G3 features a built-in TCP/IP protocol (refer to page 39) that allows for complete remote control operation of the equipment as well as direct linkage to computer-based spray controllers.

2.1 SHOTMETER-G3 PRODUCT STRUCTURE

2.1.1 MAIN COMPONENTS

Figure 1

Note

Controller's power configuration is automatic.

Auto-switch feature allows it to support 100-120 or 200-230 VAC 50-60 Hz.

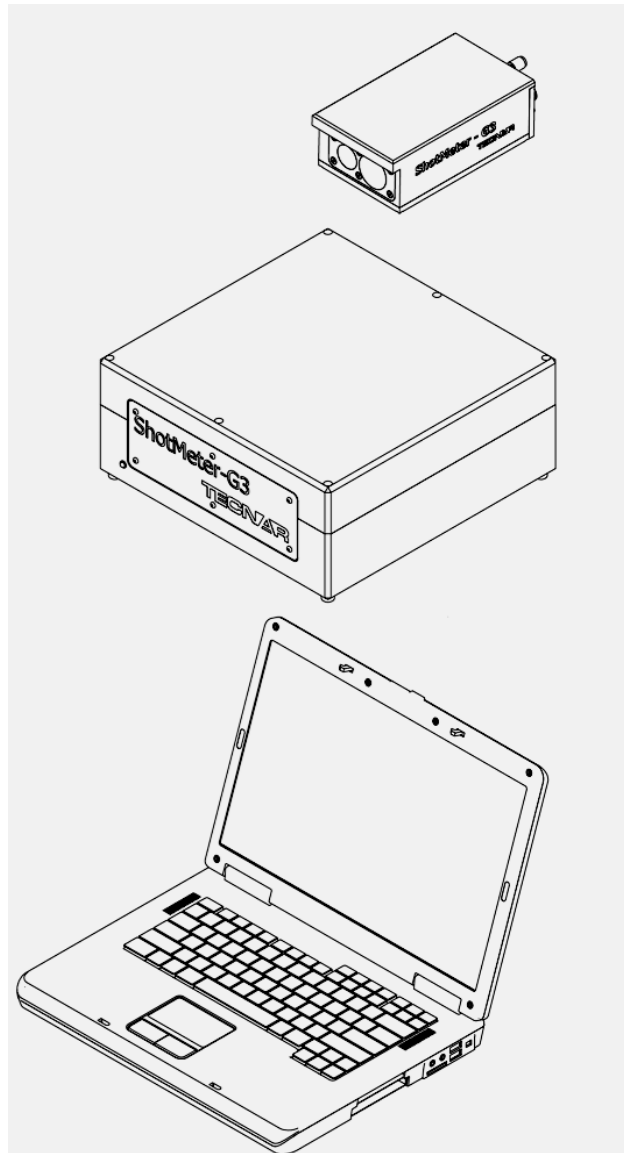

Sensor head

Controller

Computer

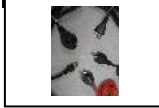

Coming
soon



2.1.2 ACCESSORIES

Software

Windows 7 operating system with license.

Spare parts (fuses)

Fuses as substitute.

Power cable

Power supply mains to controller and computer.
(Appropriate type for local electrical net conditions)

Sensor head cable

Sensor head to controller connection.

Air hose with valve

Cooling device for sensor head.

Carrying case

Carrying device for Shotmeter-G3.

Alarm box

(Optional)

Light and sound alarm device.

2.2 CONTROLLER CONNECTIONS

Figure 2

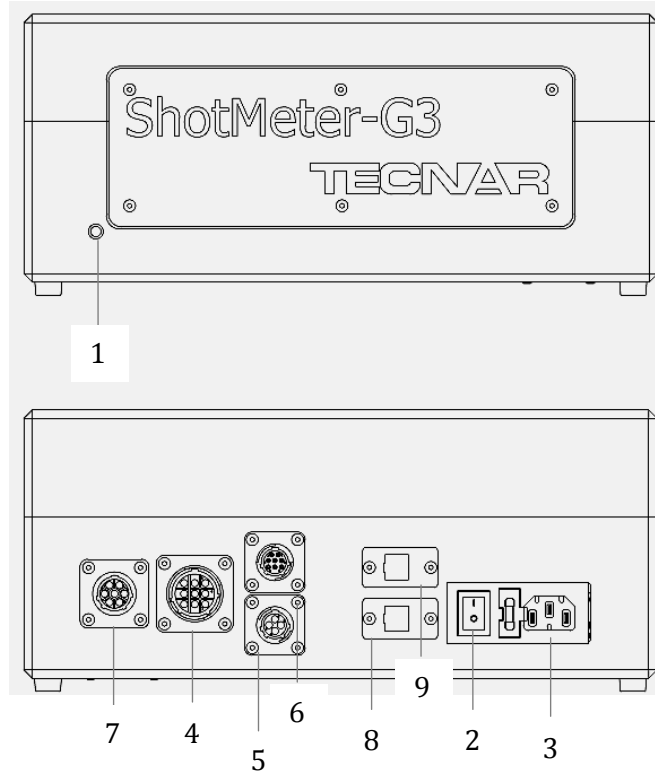

1. Power on LED indicator
2. Power switch
3. Power supply connector
4. Multiple outputs
5. Head sensor power supply
6. Lamp power connector
7. Alarm box output
8. Ethernet port for controller board
9. Ethernet port for computer

Figure 3

Note

The male/female arrangement prevents mix-ups between cables.

2.3 SENSOR HEAD CONNECTIONS

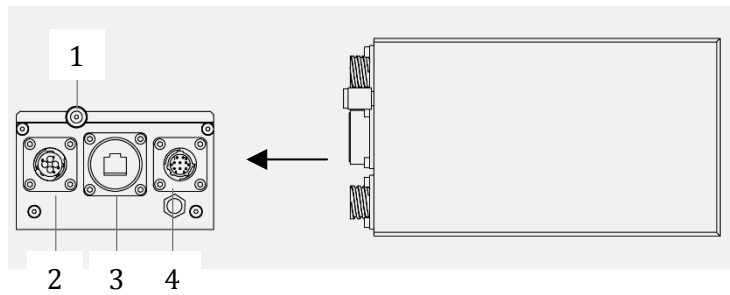

1. Air purge connector
2. Lamp power connector
3. Control board Ethernet port
4. Power supply connector

Figure 4

2.4 SENSOR HEAD WINDOW

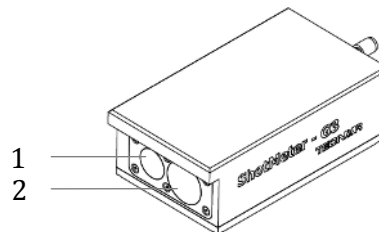

1. Speed sensor viewport
2. Lamp illumination viewport

2.5 CONTROLLER FUNCTION

The controller is the main power supply for the sensor. It combined all the signal from the sensor head to the computer through the user interface (refer to page 20). The graphical user interface displays all data relevant to the measured process.

2.6 SENSOR HEAD FUNCTION

Figure 5

Digitized sensor signal displayed on user interface

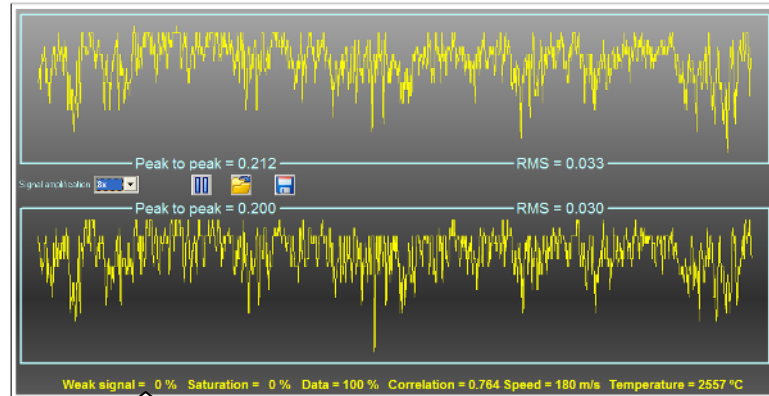

Detected signals

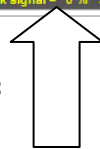

Sensor head

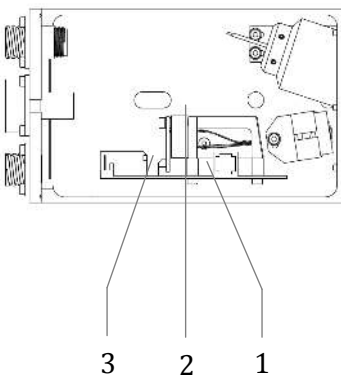

Spray

Spraying direction

2.6.1 PARTICLE VELOCITY MEASUREMENT

Shotmeter-G3's dual fibre optic device (1) "sees" the particles flow at two different measuring points (A, B) along the spray stream. Two brightness signals detected by a sensor (3) a few millimetres apart allow for the calculation of a very precise time delay value through cross-correlation analysis. The velocity can then be calculated from this time delay since the gap between the two measuring points is precisely known and constant.

2.7 DATA FLOW WITHIN CONTROL ARCHITECTURE

Figure 6

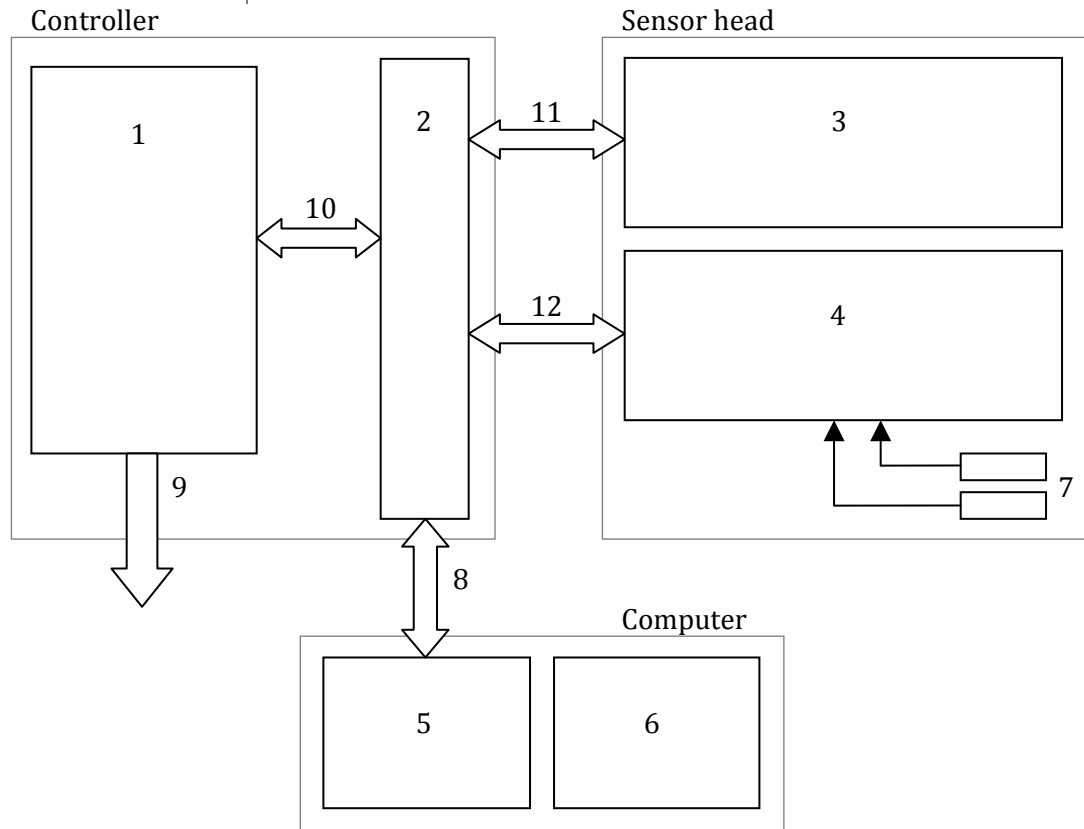

1. Controller board
2. Hub
3. Lamp for particles illumination
4. Microcontroller
5. Computer CPU
6. Computer GUI
7. Twin sensor channels
8. Ethernet link (10, 12)
9. Sensor power (lamp and sensor,11)

2.7.1 ADDITIONAL EXPLANATIONS

The microcontroller (4) acquires analog sensor signals (7). It controls the signal gain. Note that it contains all the required calibration information and additional information like the product serial number.

The controller board (1) controls the outputs and the alarms.

The computer CPU (5) controls all the equipment parameters. Adjustable parameters are determined through the graphical user interface (6). Measure readings are provided through the graphical user interface. Data communication to and from the computer CPU is supported by Ethernet links (8, 10, 12).

2.8 TECHNICAL DATA

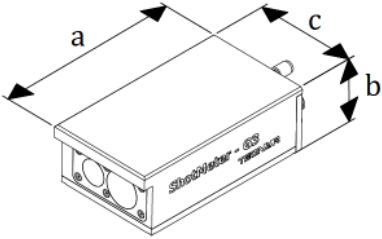
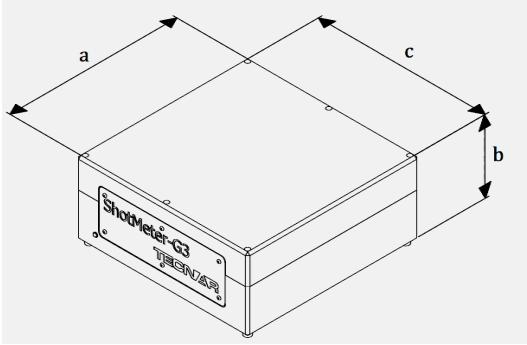
<p>Standalone system including</p> <ul style="list-style-type: none"> - Sensor head - Controller - Computer - Small parts 	<p>Carrying case dimensions and weight To follow</p>
<p>Sensor head Dimensions</p> <p>Width 105 mm (a)</p> <p>Height 65 mm (b)</p> <p>Length 185 mm(c)</p> <div style="text-align: right;">  <p>Figure 7</p> </div> <p>Weight 1.6 kg</p> <p>Working distance from spray gun axis 200 mm</p> <p>Particle velocity measurement range 0.5% precision</p>	
<p>Controller Dimensions</p> <p>Width 300 mm (a)</p> <p>Height 127 mm (b) <i>(133.35MM with bumpers)</i></p> <p>Length 300 mm(c)</p> <div style="text-align: right;">  <p>Figure 8</p> </div> <p>Weight 7 kg</p> <p>Power requirements 100-120 or 200-230 VAC, 50-60 Hz Auto-switch</p>	
<p>Computer Minimum screen resolution Power requirements</p>	<p>1024 x 768 100-120 or 200-230 VAC, 50-60 Hz</p>

CAUTION

3 INSTALLATION AND COMMISSIONING

Step 1

Mount sensor head (1) on tripod or other customer specific support device. The sensor head can be set on either side of the spray plume between the spray gun (2) and the work piece (3).

Cooling air must always be fed into air purge connector at 1.7-2.7 bar (25-40 PSI)

Figure 9

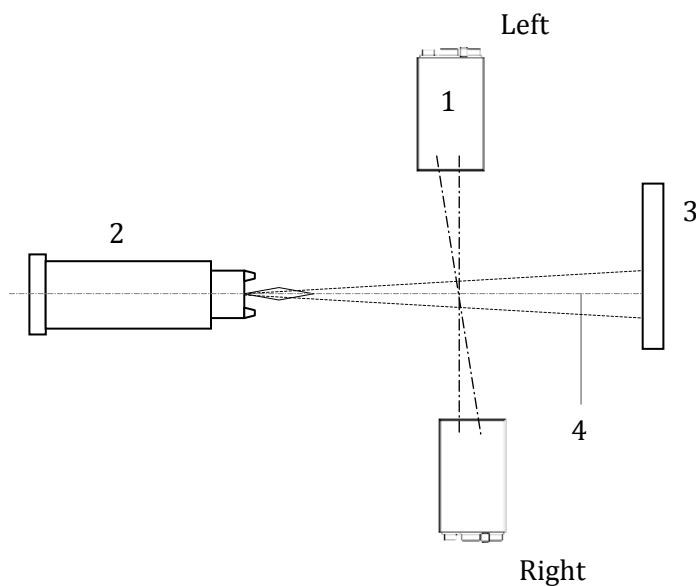

Step 2

Position sensor head 200 mm (8) & 90 degrees from the plume axis (4).

Step 3

It is not necessary to take the reference measurements at the exact same stand-off you use for peening/blasting, as long as you keep the reference distance (6) constant over time.

Figure 10

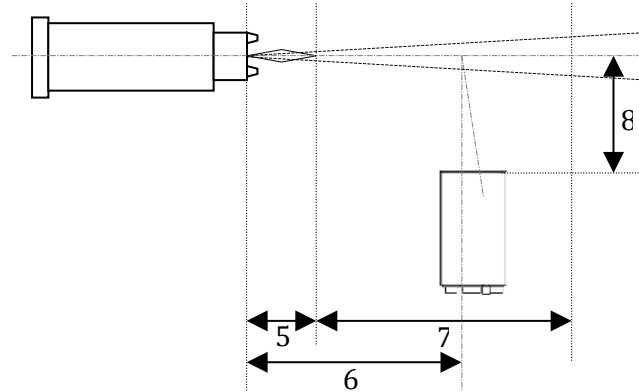
**Step 4**

If monitoring is required while actually peening/blasting the part, set measuring point within measuring area (7), away from the substrate because of flow perturbation phenomena as the spray hits the substrate.

Step 5

Connect all cables and cooling hose (refer to page 10).

Step 6

Switch on controller main switch.

Step 7

Acknowledge Windows user password window by pressing the [ENTER] key. Windows boots and the desktop will be displayed.

Enter password if required.

Step 8

Start Shotmeter-G3 software by double-clicking the corresponding icon on the desktop. After system communication check out is completed, the graphical user interface (refer to page 19) will be displayed. If check out fails, an error message window with information concerning the problem appears.

Step 9

Acknowledge error message. The software is running down after acknowledgement.

Step 10

Check system cable connections and reboot software.

Step 11

Place sensor head vertically so that the particle sensor aims at the center of the plume.

4 MAINTENANCE

4.1 REPLACEMENT OF SENSOR HEAD WINDOW

Step 1

Loosen the six locking screws on the sensor head front panel and remove the window assembly (see spare parts list in APPENDIX)

WARNING

Do not open sensor head.

Step 2

Using gloves in order not to put grease or dirt on the glass, install a new window on the sensor head front panel and gently tighten the six locking screws.

Figure 11

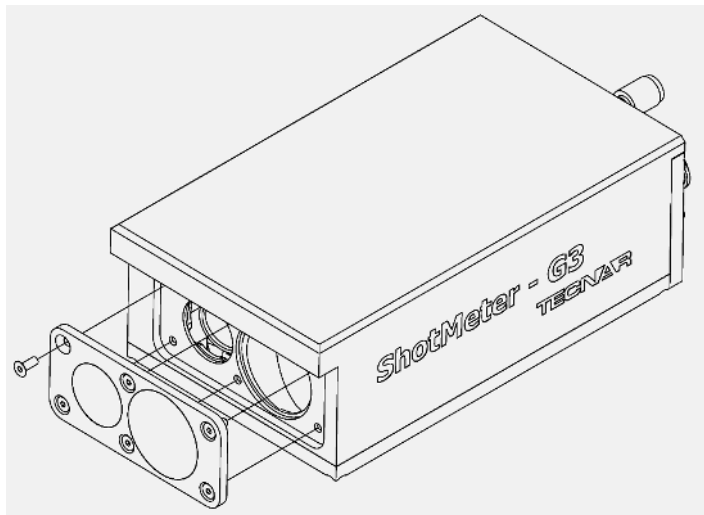

5 OPERATION

Controller must be switched ON at least one (1) minute prior to taking any measurement.

5.1 MAIN SCREEN

The main screen is divided into the following areas:

- (1) Main screen
- (2) Particle speed gauge
- (3) Strip chart

Figure 12

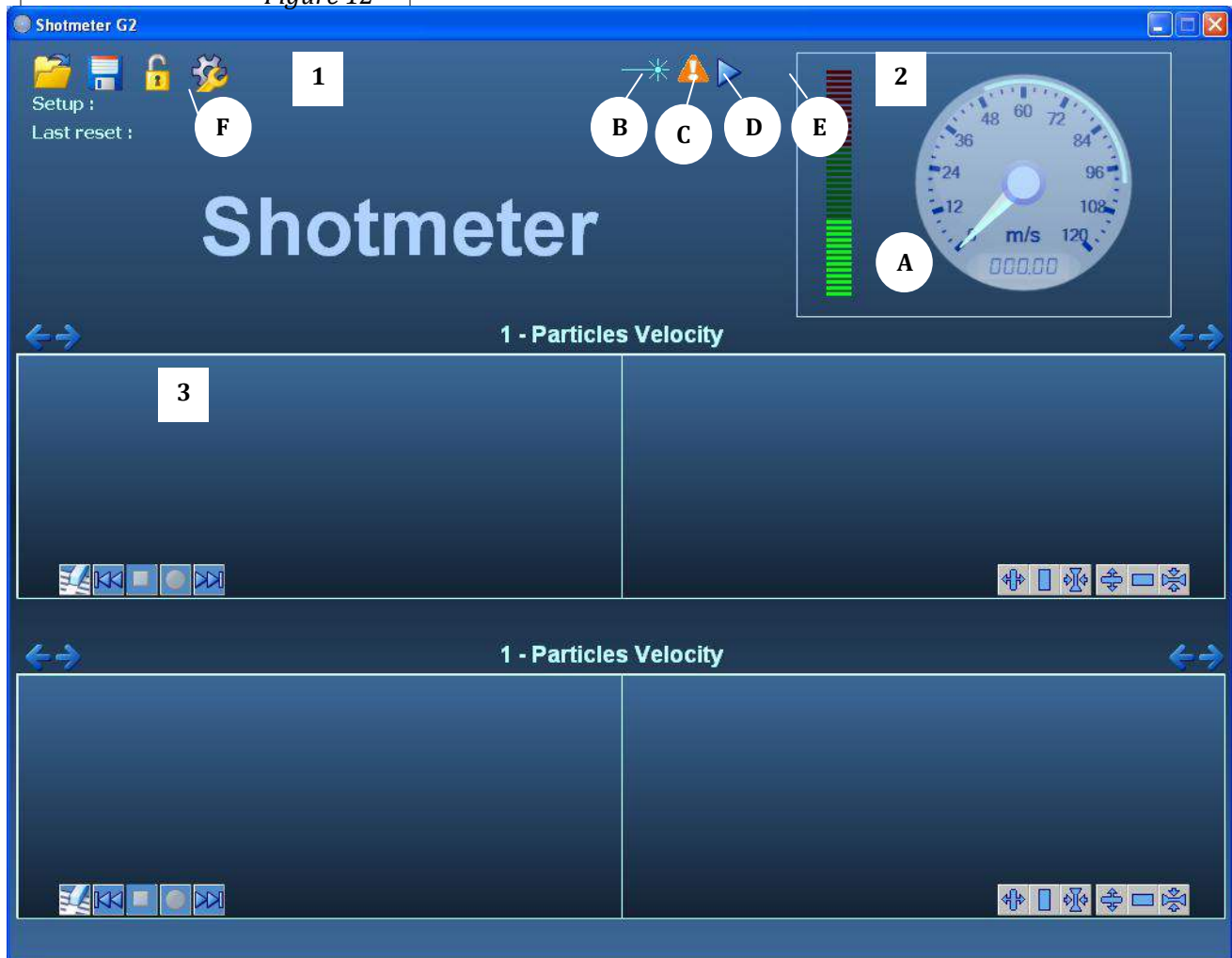

Note

In this section, the term button refers to on-screen buttons represented by icons.

5.1.1 MAIN SCREEN

This screen (1) displays the menu to control and monitor the spray. It shows the following elements:

(A) Particle VELOCITY gauge (m/s)**(B) Light-emitting diode**

The LED is used to adjust sensor head and spray gun during installation .

Clicking this button switches the alignment light-emitting diode on or off (toggle button).

(C) Alarm

This button enables or disables the alarm protocol.

(D) Play/pause

This button sets gauges, plume profile and plume video image to play (active) or pause (freeze). Data acquisition is not interrupted.

(E) Stop

This button is present only during an experiment file (*.ex) is being played. Pressing this button stops the reading.

(F) File and settings menu icons (refer to page 22)

5.1.2 STRIP CHART

Figure 13

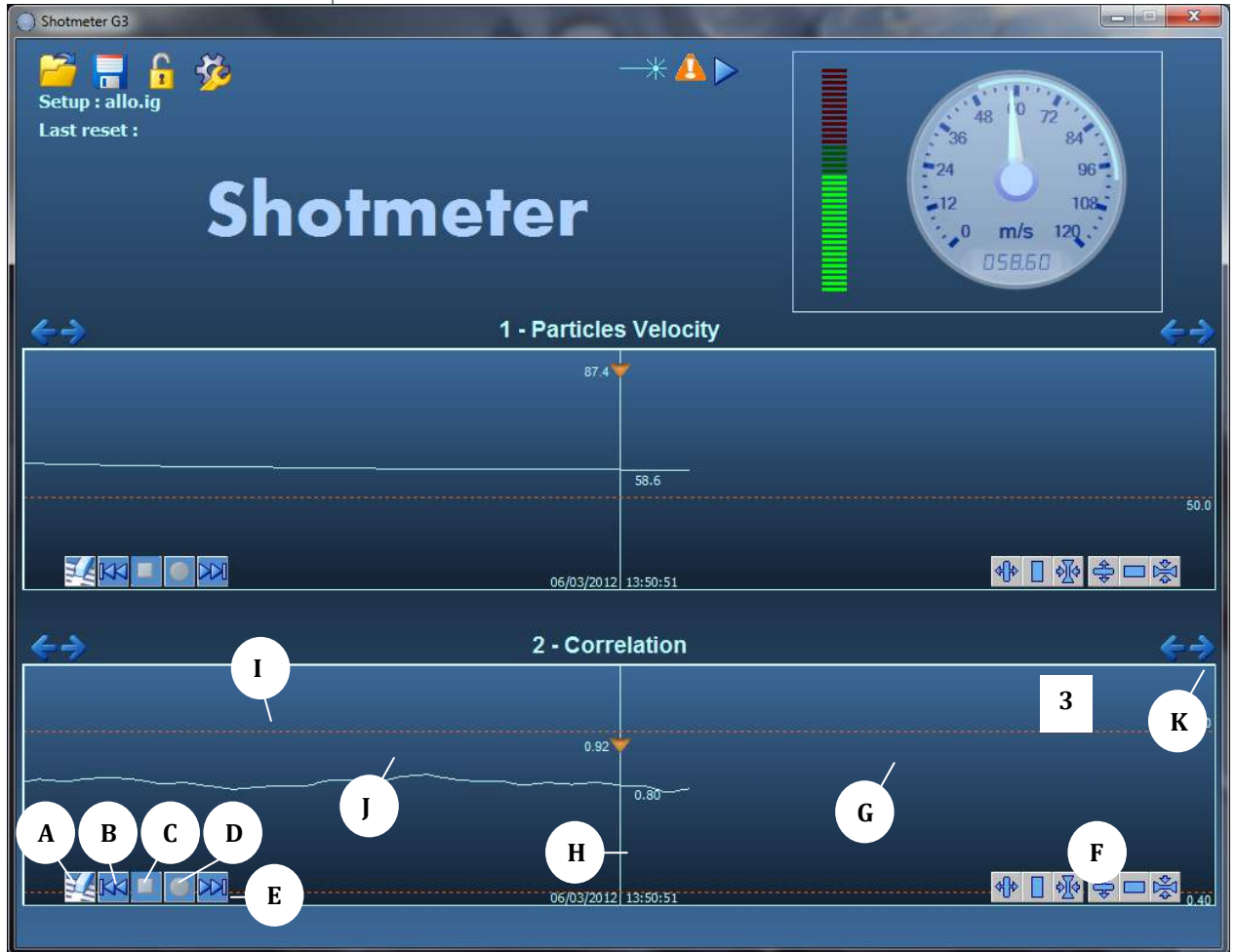

This section of the screen (3) displays strip charts (J) showing the evolution over time of any of the three measured parameters displayed in this area (in the present case, the particles velocity parameter and the correlation parameter). Two (2) stripcharts can be displayed at the same time. The buttons (K) allow the user to scroll in between each of the three parameters.

The numerical value of the trace at the point where it intersects with the vertical center (H) line is displayed. The values of the maximum and minimum excursions since the last reset are also indicated. When data acquisition is active, the center line (H) corresponds to the current time. When stopped, the trace can be

panned with a simple click and horizontal drag of the mouse to any moment in the file.

The two dotted orange lines (G) delimit the acceptable range. When the trace crosses outside these lines, the exceeding portion is displayed in orange (I) instead of the regular blue when it is within the acceptable range (J), which perfectly reflects the orange & light blue on the gauges.

The following icons control the data acquisition and display:

(A) Data eraser

This button erases all currently displayed data. Saved data are not affected.

(B) Back

This button brings back the display to the beginning of the file. It works only if the data acquisition is stopped.

(C) Stop

This button stops the file recording.

(D) Recording indicator

This icon blinks (red) when a file is recorded (for example, following a “save strip chart file” instruction).

(E) Forward

This button brings back the display to the end of the file again. It works only if the data acquisition is stopped.

(F) Control icons

These buttons control vertical and horizontal scaling of the display. The center buttons bring back default values.

Figure 14

Note

File types are automatically linked to appropriate folders (see appendix) in the Accuraspray-G3C main folder.

Note

Raw data scope signals (*.raw) can be loaded from the “Scope signals panel” described in page 37.

Note

The lock/unlock icon (C) leads to a popup prompting the user for a password granting the right to operate the Accuraspray-G3C.

CAUTION

5.2 MENUS



5.2.1 FILE MENUS

The following file types can be loaded/retrieved through the “Load File Menu” (A) and saved through the “Save File Menu” (B):

Spray instruction files (*.ig)

These files contain general instructions for thermal spray process control. That is to say all the settings required (application settings, minimum and maximum acceptance range settings, and alarm settings) are saved in this type of file.

After a load, the software performs the analysis based on the settings saved in the file. Note that these files include no measured values except for the reference profile.

Production files (*.prd)

These files contain all the current measured values and settings at the time the “Save Production File” option was selected.

Strip chart files (*.str)

Strip chart files contain the data required to plot all nine parameters charts (including correlation values). These charts can also be saved in comma-separated value (*.csv) files (from “Application Settings” panel described in page 34) for easier import in spreadsheet software for further processing or analysis. Note that when user loads a strip chart file, a popup is displayed to provide a saving option regarding the current strip chart.

Experiment files (*.ex)

The experiment files are a complete recording of a live experiment, including the video images captured by the CCD camera. Beware that such experiment files can become huge rapidly!!!

5.2.2 PADLOCK

In order to get access to the settings menus, the user must first click on the padlock **(C)** (which is locked by default) and then type in the password.

The default password is: tecnar (CAPS insensitive)

The password can be changed by the user.

5.2.3 SETTINGS MENU

The settings menu is used to navigate through the user adjustable settings windows. These settings windows are described in further details in section 5.3 (refer to page 29).

The following keyboard shortcuts are available to select settings menu items:

(F5) “Min-Max Settings”

This shortcut displays the minimum and maximum adjustment panel on screen 1.

(F6) “Alarm Settings”

This shortcut displays the alarms settings panel on screen 1.

(F7) “Application Settings”

This shortcut displays the analysis parameters adjustment panel on screen 2.

(F8) “Reaction Time Setting”

This shortcut displays a popup on the right side of the main screen allowing for the reaction time setting by means of a single cursor.

(F9) “Scope Signal Settings”

This shortcut displays the scope signals settings window on both screen 1 and screen 2.

5.3 SETTINGS

5.3.1 MINIMUM AND MAXIMUM ADJUSTMENT PANEL

Figure 15

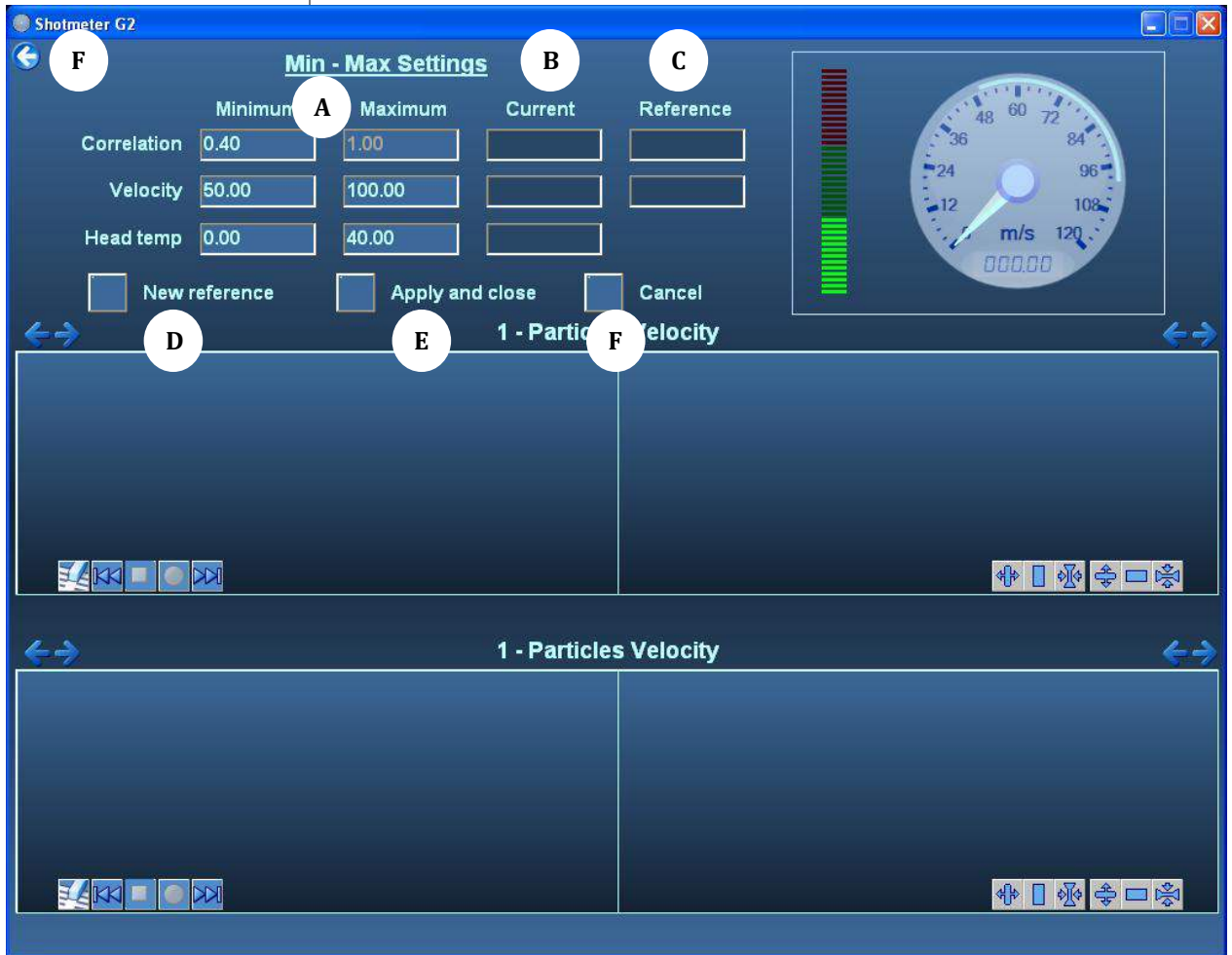

(A) Minimum and maximum acceptable limits

These values can be edited for each parameter by clicking in the corresponding numerical field.

(B) Current

This field is for display purposes, it is non-editable.

(C) Reference

This field is for display purposes only, it is non-editable.

Reference values are a snapshot of three parameters captured at the moment a new reference profile was acquired.

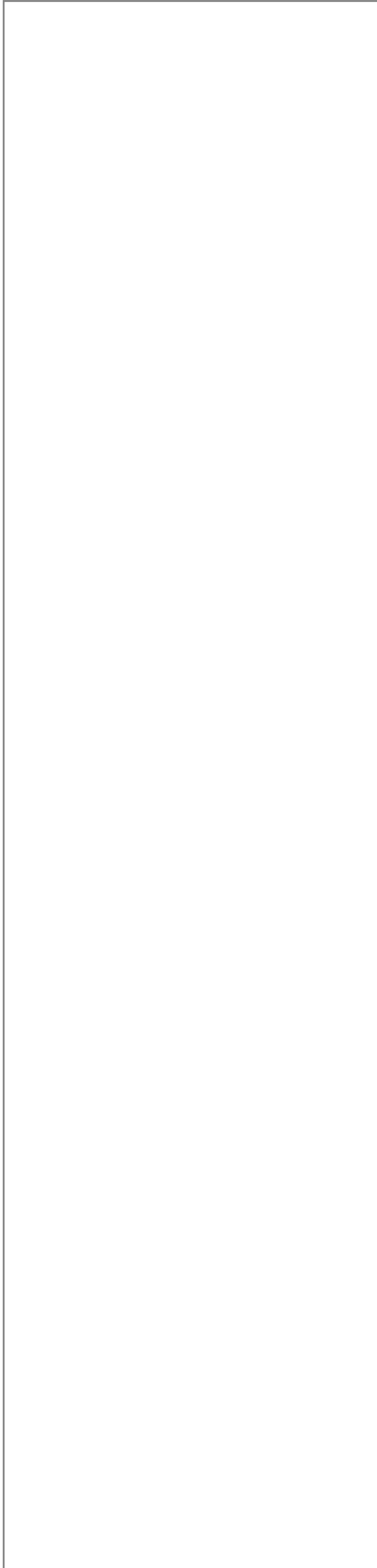
**(D) New reference**

Clicking on this button triggers the acquisition of a new reference profile and changes the reference values accordingly. Simultaneously, the plume profile changes color to yellow.

(E) Apply and close

This button is used to apply a new reference profile and close the panel.

Note that if settings are not valid for proper operation, a warning popup (refer to appendix for main popup windows explanation) is displayed and the parameters causing problem are highlighted in red.

(F) Cancel and left arrow

These buttons return to normal display.

CAUTION

5.3.2 ALARM SETTINGS PANEL

When any parameter falls outside tolerances, an alarm condition can be triggered. The alarm can make a popup window appear indicating the source of the alarm and also open or close a user-defined, contact closure type, digital I/O port.

Maximum load 3 W/ 24 V

Figure 16

Direct connection load
 $P < 3\text{ W} / U < 12\text{ V}$

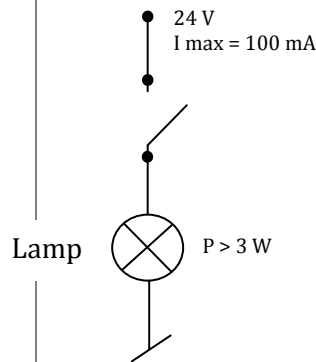

Indirect connection load
 $P > 3\text{ W} / U > 12\text{ V}$

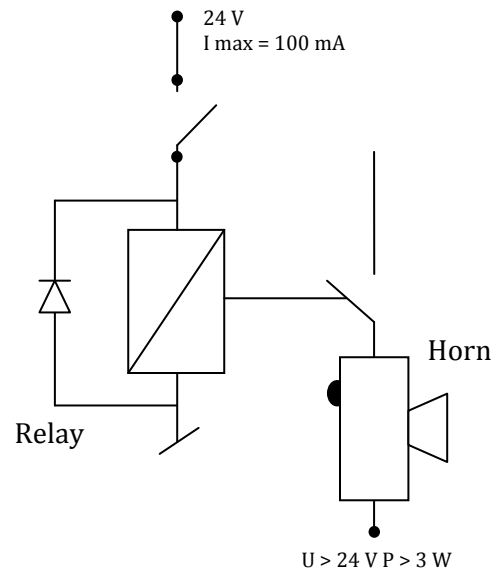
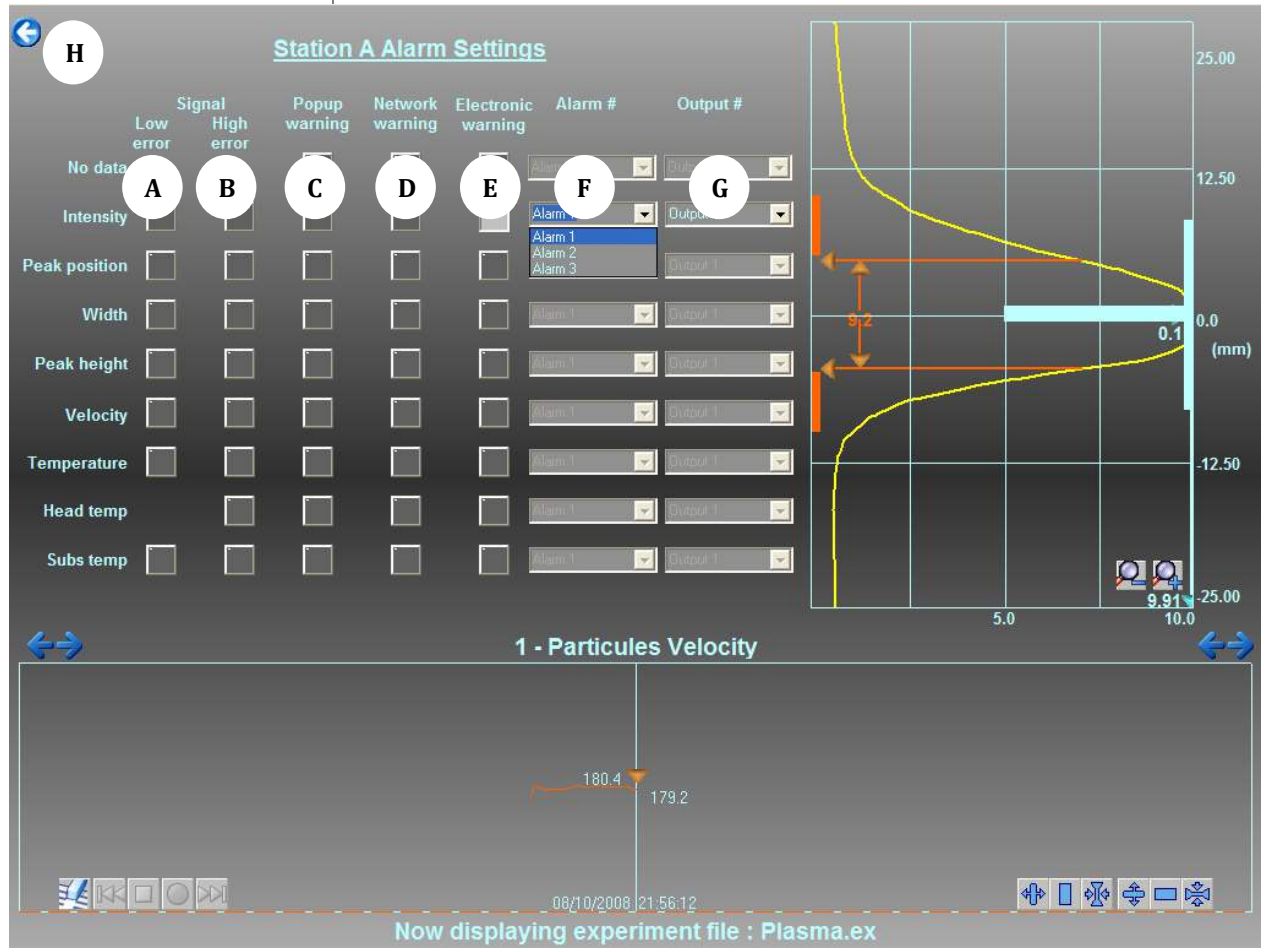

Figure 17

FIGURE USED AS REFERENCE ONLY



Except for “No data”, which is a binary condition, all parameters have the following settings:

(A) Low error

If it is selected, an alarm will be triggered when the parameter falls below its lower acceptance threshold.

(B) High error

If it is selected, an alarm will be triggered when the parameter rises above its upper acceptance threshold.

(C) Popup warning

Checking this box enables that function for the associated parameter.

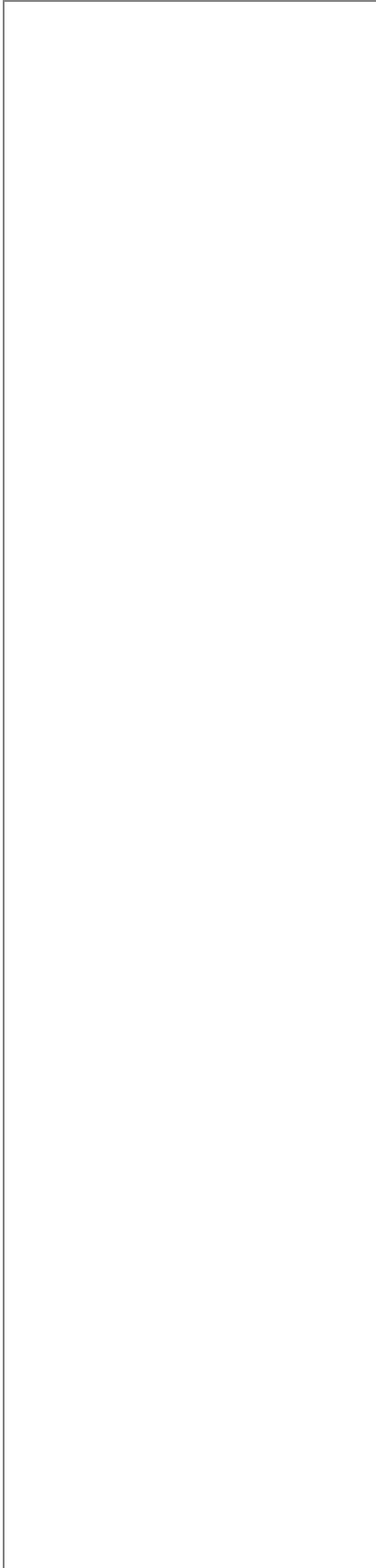
**(D) Network warning**

If it is selected, and if a connection is present on the TCP/IP command port, an alarm will be sent through the network.

(E) Electronic warning

If it is selected, activation of a digital output is enabled.

(F) Alarm #

Pull-down menu through which one of the three possible alarm outputs is selected and set to an active state.

(G) Output #

Pull-down menu through which one of the three possible outputs is selected and set to an active state.

(H) Left arrow

This button returns to normal display.

5.3.3 APPLICATION SETTINGS PANEL

This panel is divided into the two following sections:

Plume settings

General settings

Figure 18

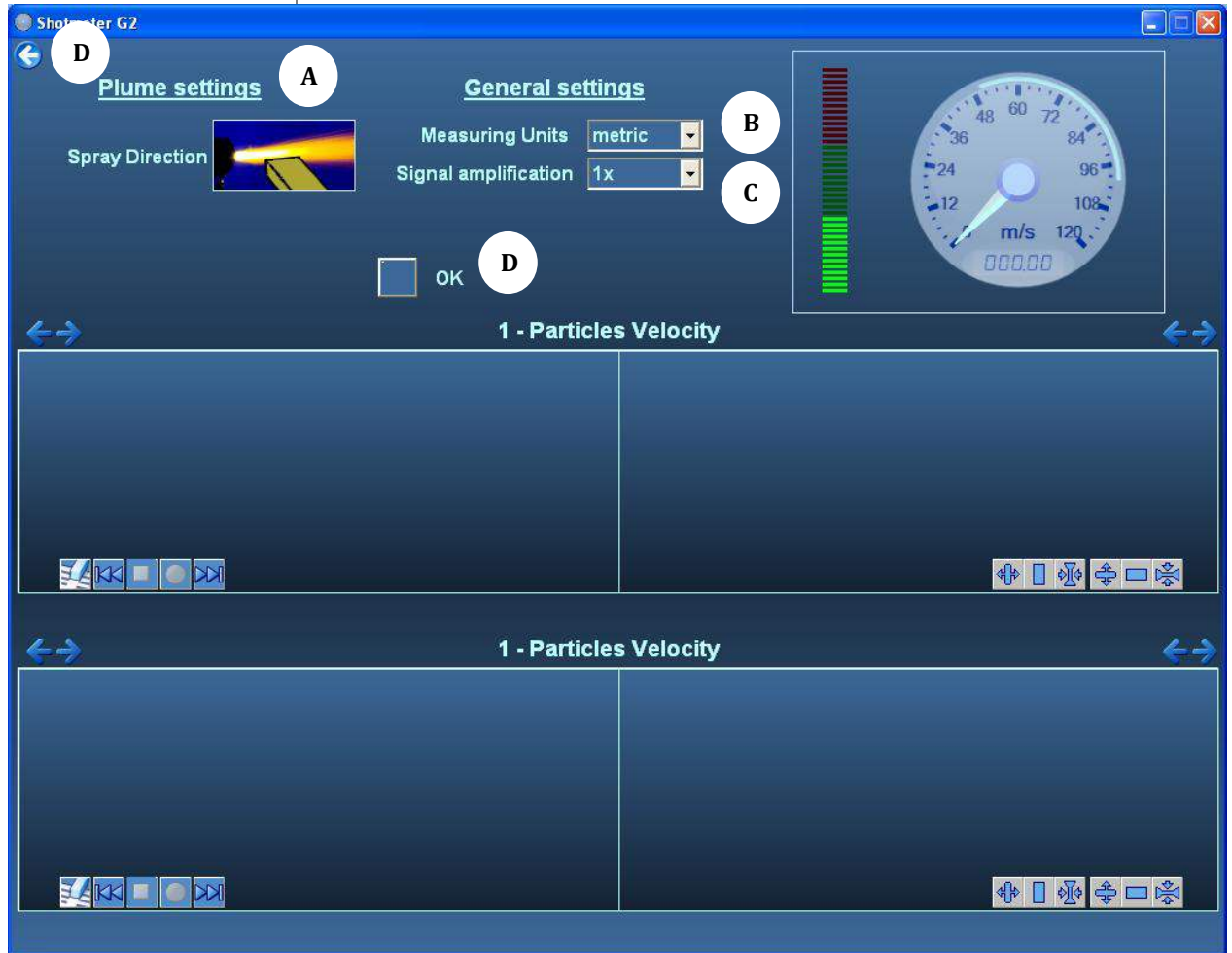

The following parameters can be edited from this panel:

(A) Spray direction

On mouse click, the image is switched horizontally. The image in this area must reflect the sensor head/gun arrangement in order to ensure proper operation of the equipment. As a matter of fact, the sensor can be mounted either on the left or on the right of the spray plume.

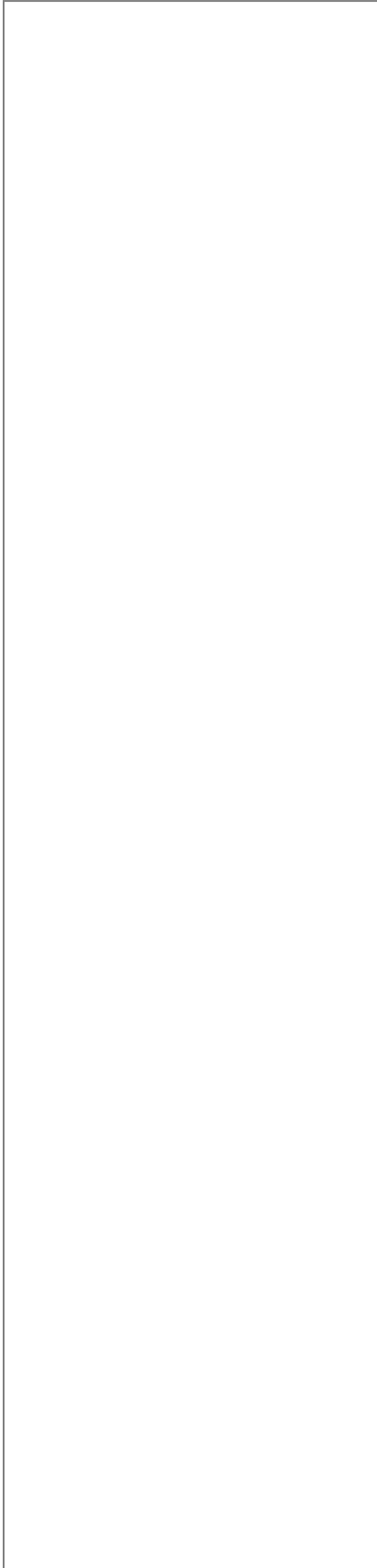
**(B) Measuring units**

This pull-down menu allows switching from the metric system to the imperial system.

(C) Signal amplification

This pull-down menu sets the amplification factor to one of eight values between 1 and 256.

(D) OK and left arrow

These buttons return to normal display.

5.3.4 REACTION TIME SETTING

FIGURE USED AS REFERENCE ONLY

Figure 19

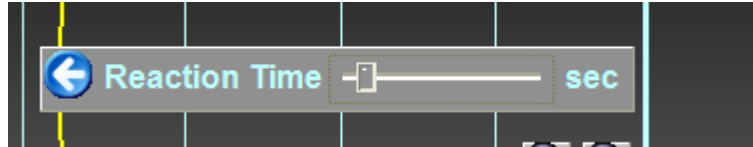

This sliding cursor determines the mean calculation time interval in seconds.

The Shotmeter OS performs a rolling average over REACTION TIME seconds. Practically, this means that if for instance you set REACTION TIME to 5s, it will take at least 5 seconds before the effect of a change in the input knobs is completely reflected into the results.

Buffer size ranges from 0 to 60 seconds.

Based on many years of field experience, a REACTION TIME on the order of 5 to 7 seconds is recommended.

5.3.5 Scope signals panel

The main function of this panel is to display the two amplified brightness signals acquired by the photodetectors.

Figure 20

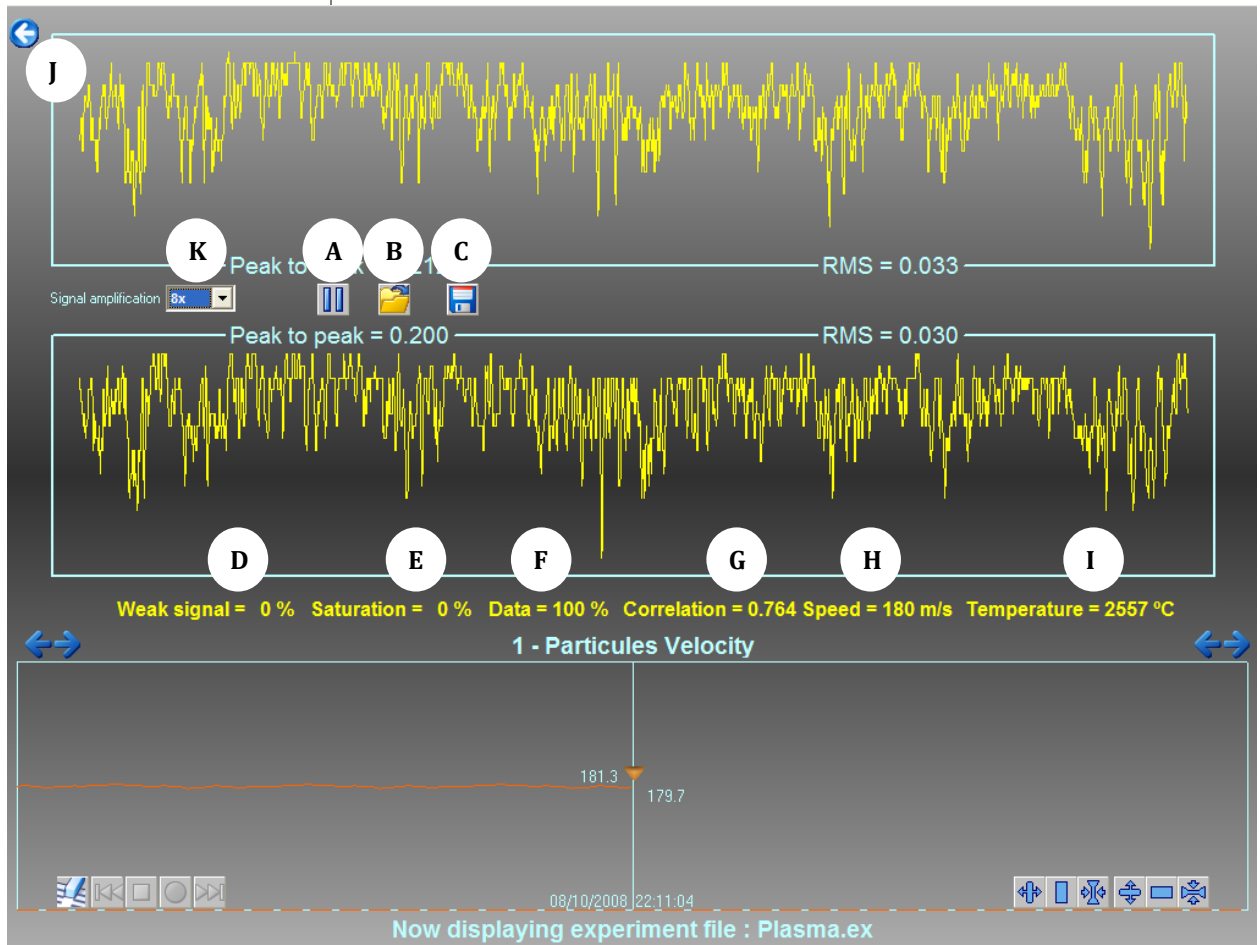

(A) Play/pause

This button activates (play) or deactivates (pause) digital scopes. Data acquisition is not interrupted.

(B) Load file

This button can be used to load previously saved raw data scope signals.

(C) Save file

This button can be used to save raw data scope signals.

(D) Weak signal

This field is for display purposes, it is non-editable. It indicates the “weakness percentage” as a function of a predetermined threshold (set in Shotmeter-G3 configuration file).

(E) Saturation

This field is for display purposes, it is non-editable. It indicates the “saturation percentage” at the analog to digital converters of the sensor head’s microcontroller.

To prevent saturation, reduce amplifier gain (K).

(F) Data

This field is for display purposes, it is non-editable. It indicates the percentage of acquired data below saturation (i.e. with 30% saturation, the data percentage should be 70%).

(G) Correlation

This field is for display purposes, it is non-editable. It indicates the cross-correlation value.

(H) Speed

This field is for display purposes, it is non-editable. It indicates the current particles speed.

(I) Temperature

This field is for display purposes, it is non-editable. It indicates the current temperature of the process.

(J) Left arrow

This button returns to normal display.

(K) Gain

This pull-down menu sets the amplification factor to one of eight values between 1 and 256.

APPENDIX

MAIN POPUP WINDOWS

ERROR MESSAGES

If the following error messages appear, the operator should check if all the required cables are properly connected.

It might be necessary to restart the controller if popup appears for the second time.

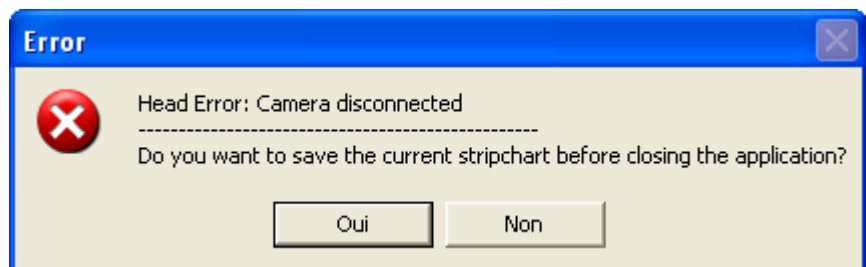
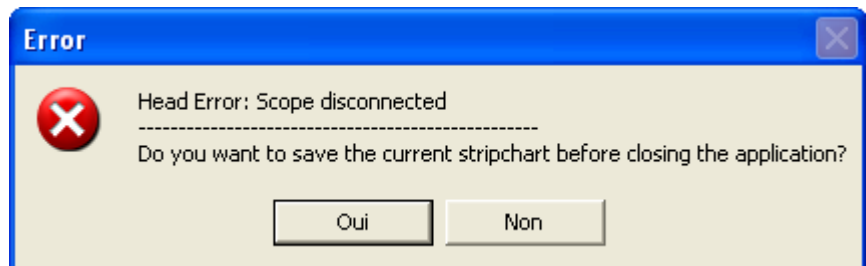
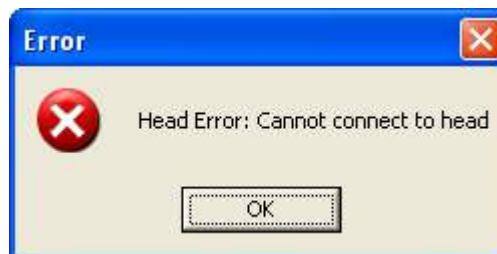

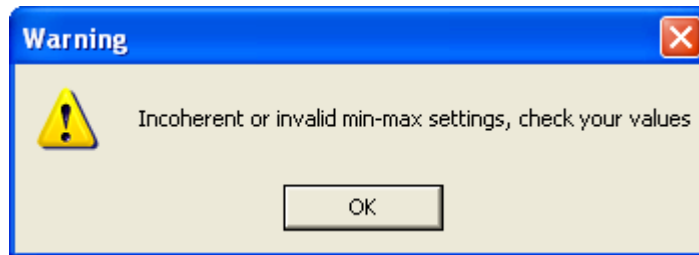
WARNING MESSAGES

If this message appears after setting minimum and maximum parameters' values, it means that one parameter or more are not set properly. The operator should check the settings.

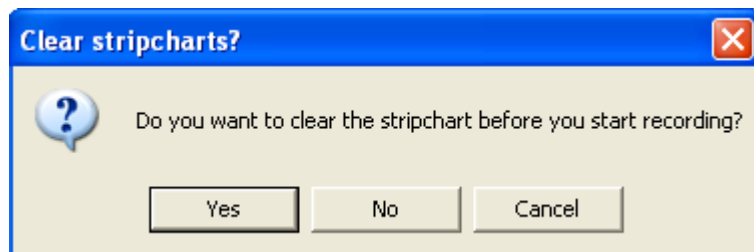

This message appears when an attempt is made to save a production file while not in live mode. For example, it is not possible to save a production file after loading an experiment file.

QUESTION PROMPT

This message appears when saving or loading a strip chart file.

FOLDER CONFIGURATION

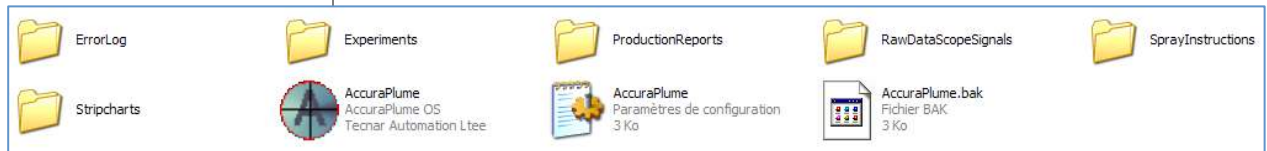

This screenshot illustrates the folder organization of Shotmeter-G3 main folder.

ErrorLog

This folder contains error logs as HTML files describing the technical environment at the time a bug occurred.

Experiments

This folder contains experiment files (*.ex) and is linked to associated save and load instructions.

ProductionReports

This folder contains production files (*.prd) and is linked to associated save and load instructions.

RawDataScopeSignals

This folder contains raw data scope files (*.raw) and is linked to associated save instruction.

SprayInstructions

This folder contains spray instruction files (*.ig) and is linked to associated save and load instructions.

StripCharts

This folder contains strip chart files (*.str) and is linked to associated save and load instructions. It also contains the comma separated value files (*.csv).

Files

- AccuraPlume.exe: Shotmeter-G3 software executable file
- AccuraPlume.ini: Shotmeter-G3 software configuration file
- AccuraPlume.bak: Shotmeter-G3 software backup for configuration file

SPARE PART

- 90221-00001, Sensor head cables bundle
- 90000-00002, Fuses kit
- 30201-00337, Spare windows assembly

TCP/IP PROTOCOL DETAIL

COMMAND MODE

PC IP
Port 1557

Notes:

- All commands are case insensitive.
- All file extensions are optional. If no file extension is given, default file extension is used.
- If a file name is given without path, default directory is used.
- "Start production" command file's name is optional. If no file name is given, default file name is used.
- Version format: x.x.x

Command	Return value
version	version[version::ok::AccuraG3C]
read inputs	read inputs[version::ok::value]
reset	reset[version::ok]
load setup[setup_name.ig]	load setup[version::ok]
enable alarms	enable alarms[version::ok]
disable alarms	disable alarms[version::ok]
live	live[version::ok::state]
live on	live on[version::ok]
live off	live off[version::ok]
start production[operator::production notes::optional_file_name.prd]	start production[version::ok]
start stripcharts recording[file_name.str]	start stripcharts recording[version::ok]
stop stripcharts recording	stop stripcharts recording[version::ok]
clear stripcharts	clear stripcharts[version::ok]
head temperature	head temperature[version::ok::value]
velocity	velocity[version::ok::value]
temperature	temperature[version::ok::value]
weak signal	weak signal[version::ok::value]
saturation	saturation[version::ok::value]
correlation	correlation[version::ok::value]

plume intensity	plume intensity[version::ok::value]
plume position	plume position[version::ok::value]
plume width	plume width[version::ok::value]
plume height	plume height[version::ok::value]
historical low head temperature	historical low head temperature[version::ok::value]
historical high head temperature	historical high head temperature[version::ok::value]
historical low velocity	historical low velocity[version::ok::value]
historical high velocity	historical high velocity[version::ok::value]
historical low temperature	historical low temperature[version::ok::value]
historical high temperature	historical high temperature[version::ok::value]
historical low correlation	historical low correlation[version::ok::value]
historical high correlation	historical high correlation[version::ok::value]
historical low plume intensity	historical low plume intensity[version::ok::value]
historical high plume intensity	historical high plume intensity[version::ok::value]
historical low plume position	historical low plume position[version::ok::value]
historical high plume position	historical high plume position[version::ok::value]
historical low plume width	historical low plume width[version::ok::value]
historical high plume width	historical high plume width[version::ok::value]
historical low plume height	historical low plume height[version::ok::value]
historical high plume height	historical high height[version::ok::value]
historical low substrate temperature	historical low substrate temperature[version::ok::value]
historical high substrate temperature	historical high substrate temperature[version::ok::value]
set output n	set output n[version::ok]
clear output n	clear output n[version::ok]
---- On error ----	command[version::Error::error number::error description]
---- On alarms ----	alarm[version::ok::alarms number list(comma separated)::alarms description list(comma separated)]
---- On invalid command----	invalid command[version::ok]

STREAMING MODE

PC IP
Port 555

Setup Requirements

The subnet mask of the Ethernet connection used for the streaming mode should be 255.255.255.0 in order to avoid the collisions with the IP addresses used within the G3 system.

Commands

SPRAYON = Start streaming
SPRAYOFF = Stop streaming

Result example:

11:04:09;658.58;366.54;1944.24;190.52;0.29;0.00;0.24;0.17;16
5.30;0.20

Hour; Velocity; STD Velocity; Temperature; STD Temperature;
Intensity; STD Intensity; Peak Position; STD Peak Position;
Substrate Temp; STD Substrate Temp

GLOSSARY / ACRONYMS

CCD camera Charge-coupled device camera	Semi-conductor camera comprising a barrier diode matrix that accumulates an amount of electrons proportional to the amount of received photons. The built image is then shifted one line at a time to an output register and an amplifier.
Correlation value	Indicative of the degree of similarity between 2 signals
CPU	Central processing unit
Cross-correlation	Method used to determine precisely the average time shift between 2 signals
Ethernet (protocol)	A family of frame-based computer networking technologies for local area networks
Giga Ethernet (protocol)	New version of the Ethernet protocol with a rate up to 1Gbits/s within a local area network
GUI	Graphical user interface
Popup window	Window appearing inside another one without user intervention, in order to question or notify the user regarding the current situation
Pyrometer	Contactless temperature measuring device
RMS value Root-mean-square value	That is to say, the square root of the mean of the squares of the time equidistant instantaneous values during one complete period
TCP/IP Transmission Control Protocol / Internet Protocol	Delivery (TCP) and transport (IP) of data packages

DESCRIPTION OF FIGURES

- Figure 1 is a drawing showing the main product components
- Figure 2 is a drawing showing a front and a rear view of the controller
- Figure 3 is a drawing illustrating the sensor head connections
- Figure 4 is a drawing illustrating the sensor head window
- Figure 5 is a drawing illustrating the sensor head function
- Figure 6 is a bloc diagram illustrating the data flow within the product's architecture
- Figure 7 is a drawing illustrating the sensor head dimensions
- Figure 8 is a drawing illustrating the controller dimensions
- Figure 9 is a drawing illustrating the product's installation process
- Figure 10 is a drawing illustrating the product's installation process
- Figure 11 is a drawing illustrating the sensor head's window removal for maintenance
- Figure 12 is a view of the main screen during normal operation
- Figure 13 is a view of the main screen during normal operation (strip chart)
- Figure 14 is a view of the graphical interface's menus
- Figure 15 is a view showing the minimum and maximum adjustment panel
- Figure 16 is a schematic illustrating the alarm output's loads

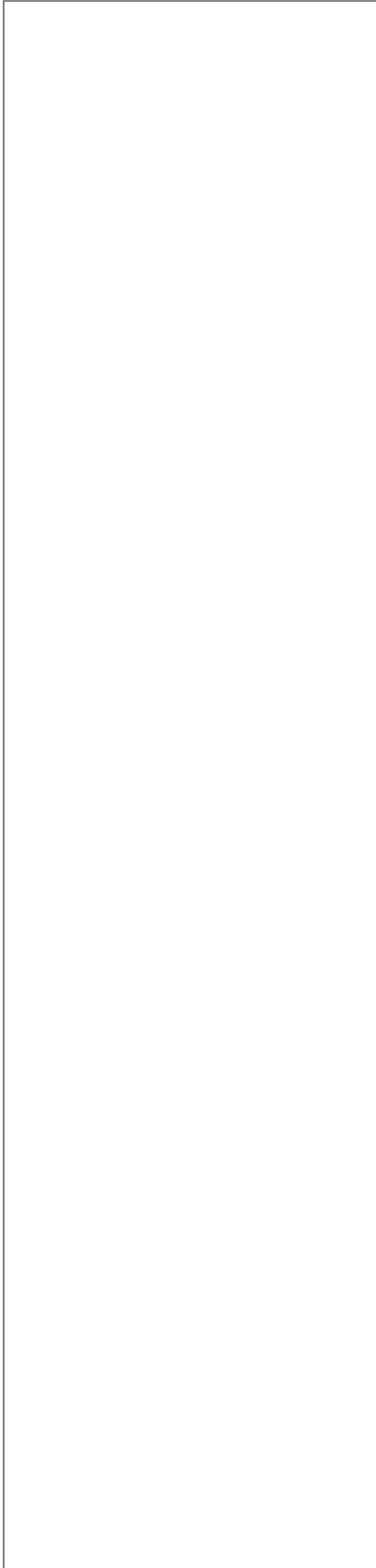

- Figure 17 is a view illustrating the alarm settings panel
- Figure 18 is a view illustrating the application settings panel
- Figure 19 is a view illustrating the reaction time setting sliding cursor
- Figure 20 is a view illustrating the scope signals panel

QUICK TROUBLE-SHOOTING

<i>Problem</i>		<i>Potential cause</i>	<i>Remedy</i>
No signal		<ul style="list-style-type: none"> • Bad alignment • Disposable protective windows are dirty or frosty 	<ul style="list-style-type: none"> • Validate the signal amplification factor • Clean or replace the windows assembly with clean air and iso-propanol • Validate the alignment

Shotmeter-G3 is a new product, therefore the trouble-shooting section will evolve over time. See following section for service & support information.

SERVICE & SUPPORT

Below are the points of contact for questions and/or service-support on Shotmeter/PlumeSpector-g3 & G3 systems.

TECNAR Automation Ltd (The original manufacturer)
1321, Hocquart Street,
St-Bruno, Qc, Canada, J3V 6B5
Phone: 450-461-1221
Fax: 450-461-0808
Email: thermalspray.service@tecnar.com

Contact names (please contact in the following order):

Mr. Bruno Paradis, Supervisor Thermal Spray production & Service (phone ext 251, bparadis@tecnar.com)

Mr. Dominic Larrivee, Calibration officer (phone ext 240, dlarrivee@tecnar.com)

Mr. Olivier Jolicoeur, Director of Production & Service (phone ext 236, ojolicoeur@tecnar.com)

Mr. Luc Pouliot, Chief Operating Officer (phone ext 235, lpouliot@tecnar.com)